

# APPROVAL SHEET

To :

Customer P/N :

UDE P/N : RUP-TD-0002

Description : RJ45 Tab up over USB3.2 Gen1 stack  
Through Hole

10G Base-T

Contact Area : 30 $\mu$ " Min. Gold

LED : L-Yellow; R-Green/Orange



Spec No.  
RUP21029-00

Update Date  
2021/3/9

Revision  
A

Approved	Checked	Prepared



湧德電子 股份有限公司  
UDE Corp.

桃園市(33852) 蘆竹區內溪路 68 巷13號

No.13, Ln. 68, Neixi Rd., Luzhu Dist., Taoyuan City (33852), Taiwan

TEL: 886-3-3242000 FAX: 886-3-3246611

<http://www.ude-corp.com/>



1. MECHANICAL DIMENSION

Product Dimension

Unit:mm	General Tolerance :	X.X : ± 0.38
		X.XX : ± 0.20

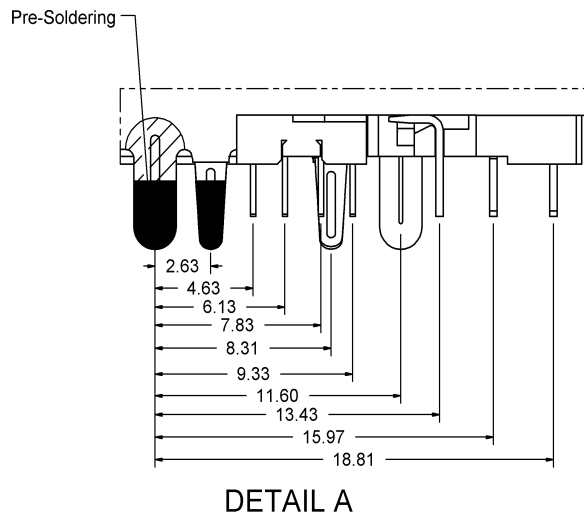
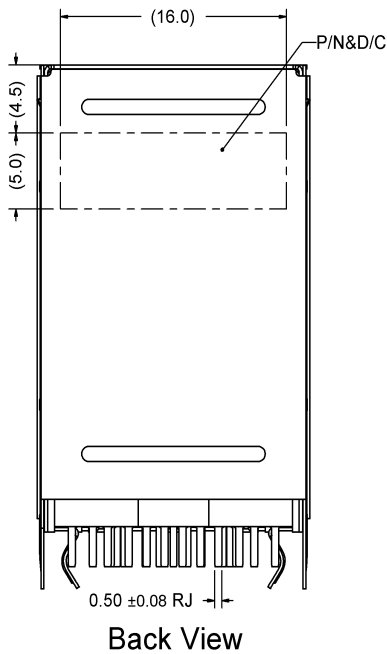
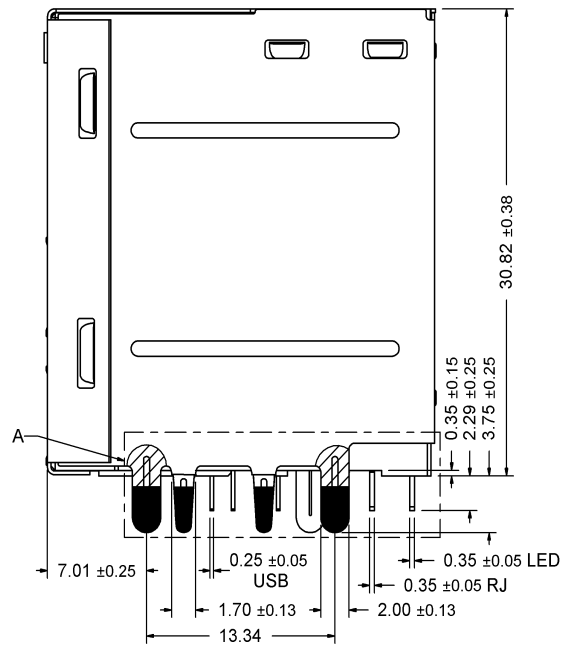
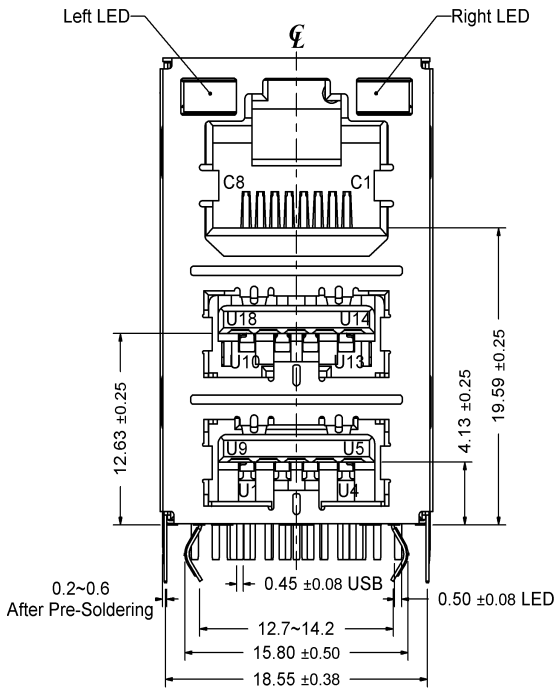
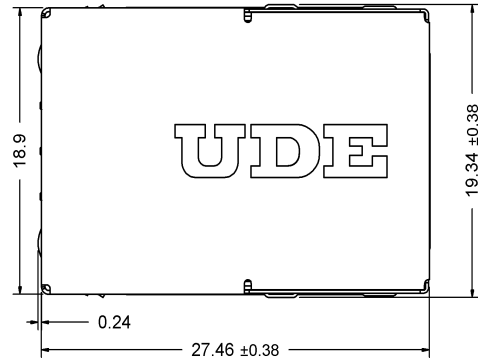
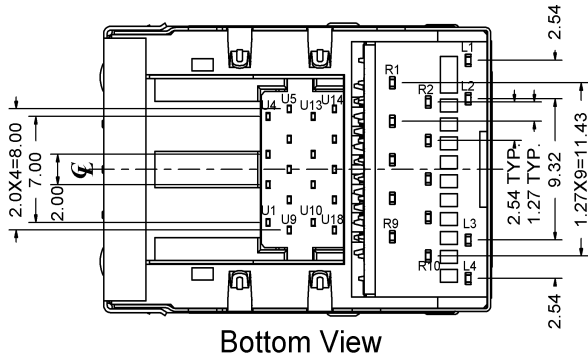

Recommended PCB Layout. Component side of board

All dimension units are "mm".

All dimension tolerances are ±0.05mm unless otherwise specified.

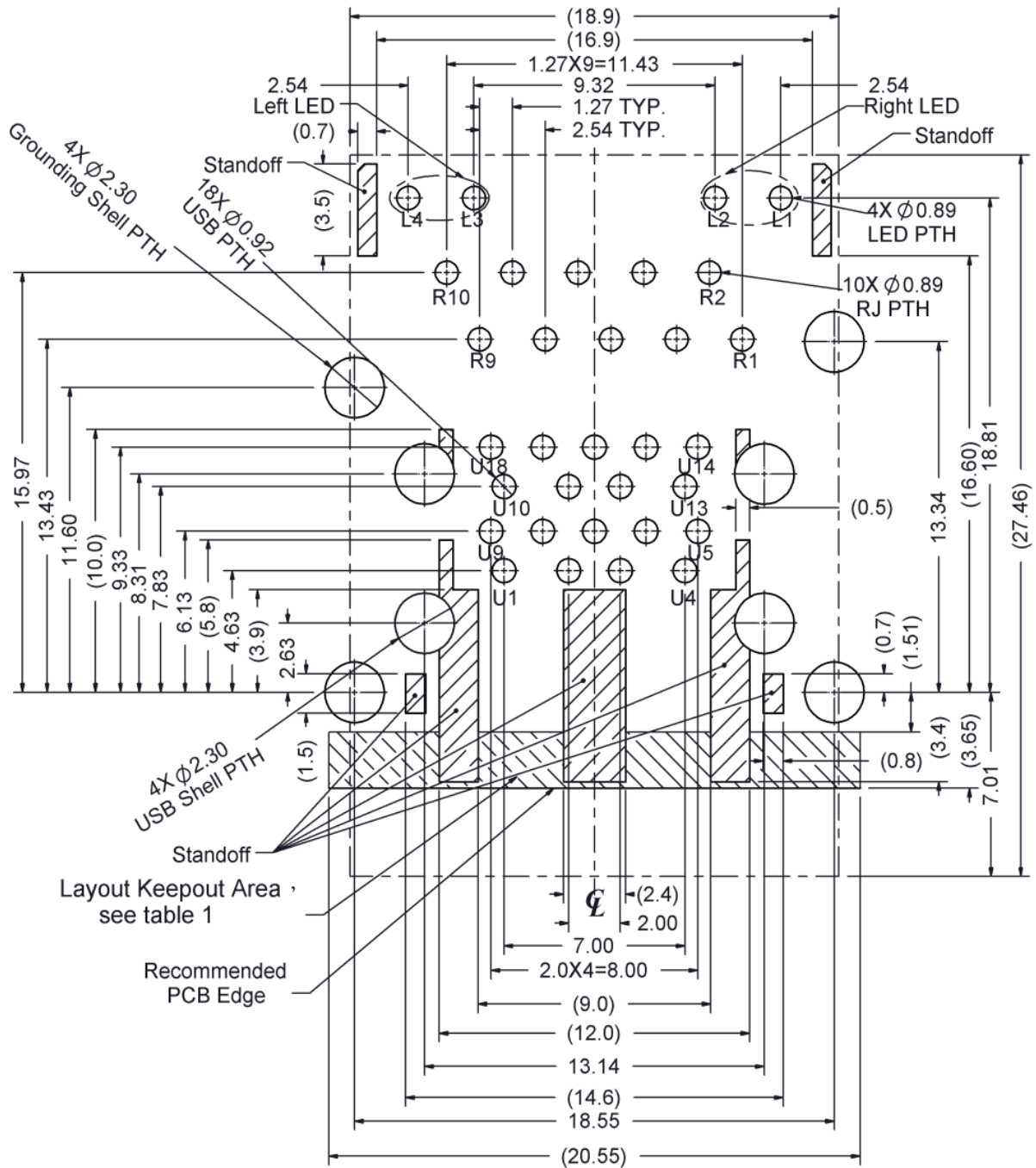
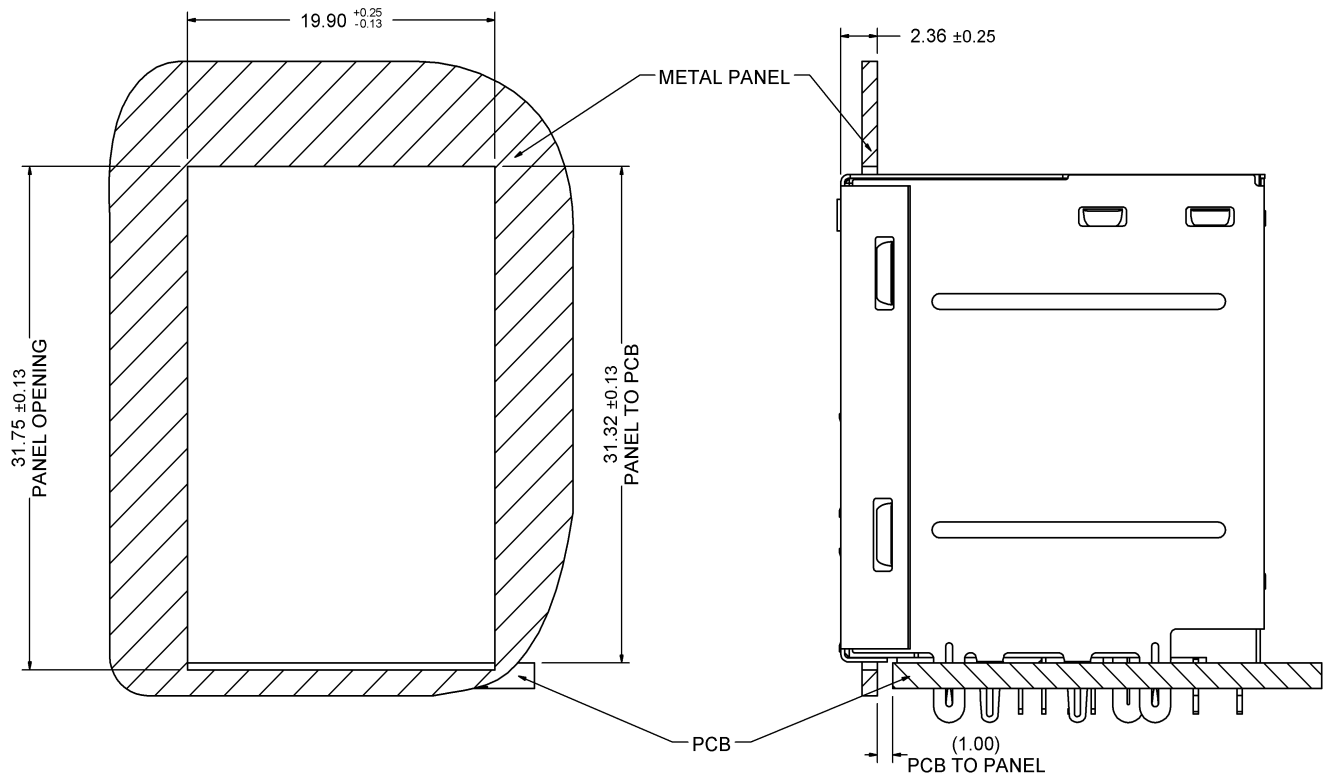

Table1

Layout Layer	Trace	component	Grounding	Test Point	Via Hole	PTH	NPTH
Component side	X	X	O	X	X	X	O
Inner layer	O	NA	O	NA	O	X	O
Bottom side	O	O	O	O	O	X	O

X--Forbid; O--OK; NA--Not Applicable.

## Recommended Panel cutout



## 2. Packing Information

40 pcs finished goods per tray

5 trays(200 pcs finished goods) per inner box

4 Inner boxes(800 pcs finished goods) per master carton



4. USB 3.2 Standard-A Plug Specification

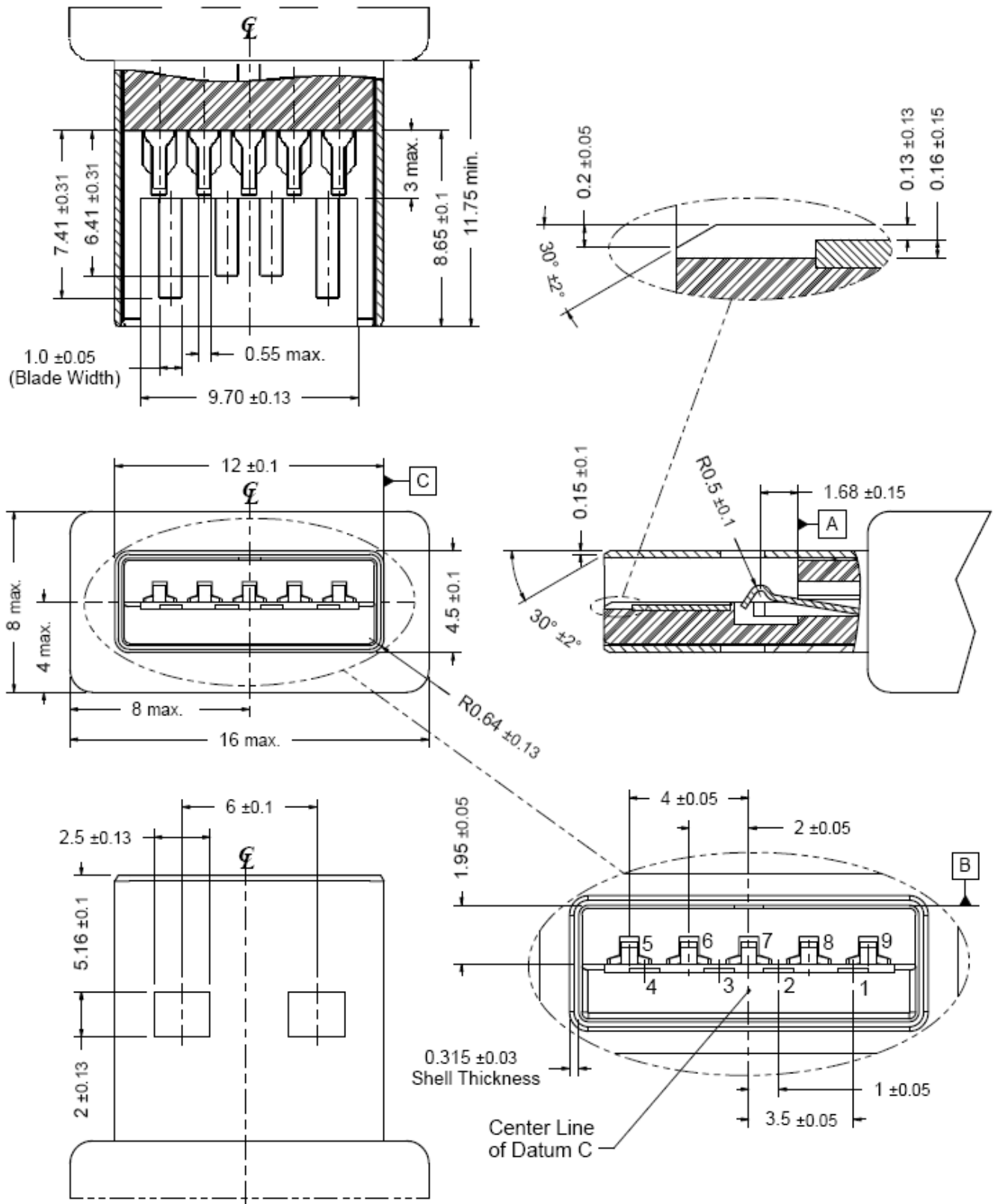

- All dimensions follow : Universal Serial Bus 3.0 Specification, Revision 1.0.

Figure 5-2. USB 3.1 Standard Plug-A interface dimensions

- Non-dimensions geometry for reference only, subject to change.
- Drawing for mating interface dimensions only.

## 5. REQUIREMENTS

### Design and Construction

Product shall be of design, construction and physical dimensions specified on applicable.

### Material

Terminal Parts (Underplating : 50 $\mu$ " min. Nickel overall)

RJ Terminal : Phosphor Bronze, Thickness=0.30mm

Finish : Contact Area : 30 $\mu$ " min. Gold

Solder Tail : 100 $\mu$ " min. Bright Tin

USB 2.0 Terminal : Phosphor Bronze, Thickness=0.25mm

Finish : Contact Area : 30 $\mu$ " min. Gold

Solder Tail : 100 $\mu$ " min. Matte Tin

USB 3.2 Gen1 Terminal : Brass, Thickness=0.25mm

Finish : Contact Area : 30 $\mu$ " min. Gold

Solder Tail : 100 $\mu$ " min. Matte Tin

Input Terminal : Brass, Thickness=0.35mm

Finish : 100 $\mu$ " min. Matte Tin

Case Terminal : CP Wire, Diameter=0.40mm

Finish : 100 $\mu$ " min. Bright Tin

LED Terminal : Brass, Thickness=0.35mm

Finish : 100 $\mu$ " min. Matte Tin

Plastic Parts <UL94V-0>

RJ Housing : PBT, Black

Spacer : PBT, Black

Case : PF2A5-151J(b), Black

USB Housing : PA9T, Blue(300C)

USB Back Cover : PA9T, Blue(300C)

Shield Parts

Front Shield : Stainless Steel, Thickness=0.25mm, unplating

Back Shield : Stainless Steel, Thickness=0.20mm, Pre-soldering



## 6. Operating and Storage Temperature

Operating Temperature : 0°C to +70°C

Storage Temperature : -40°C to +85°C

## 7. RJ45 specifications

Insulation Resistance : 500MΩ min.

Insertion force with the latch depressed : 20N max.

Removal force with the latch depressed : 20N max.

Locking Force of Plug Latch : 50N min. @ 60+/-5 sec.

Durability : 2500 cycles

## 8. USB 3.2 Gen1 specifications

Insulation Resistance : 100MΩ min.

Dielectric Withstanding Voltage : 100VAC @1min

Insertion force : 35N max

Removal force : The connector extraction force shall not be less than 10N initial  
and 8N after the specified insertion/extraction or durability cycles

Durability : 1500 cycles

## 9. Performance and Test Description

Product is designed to meet electrical, mechanical and environmental performance requirements specified in below table.

All tests are performed at ambient environmental conditions per MIL-STD-1344A and EIA-364 unless otherwise specified.

## 10 Packaging and Packing

All parts shall be packaged and packed to protect against physical damage, corrosion and deterioration during shipment and storage.

11. USB 3.2 GEN 1 Standard-A Schematic

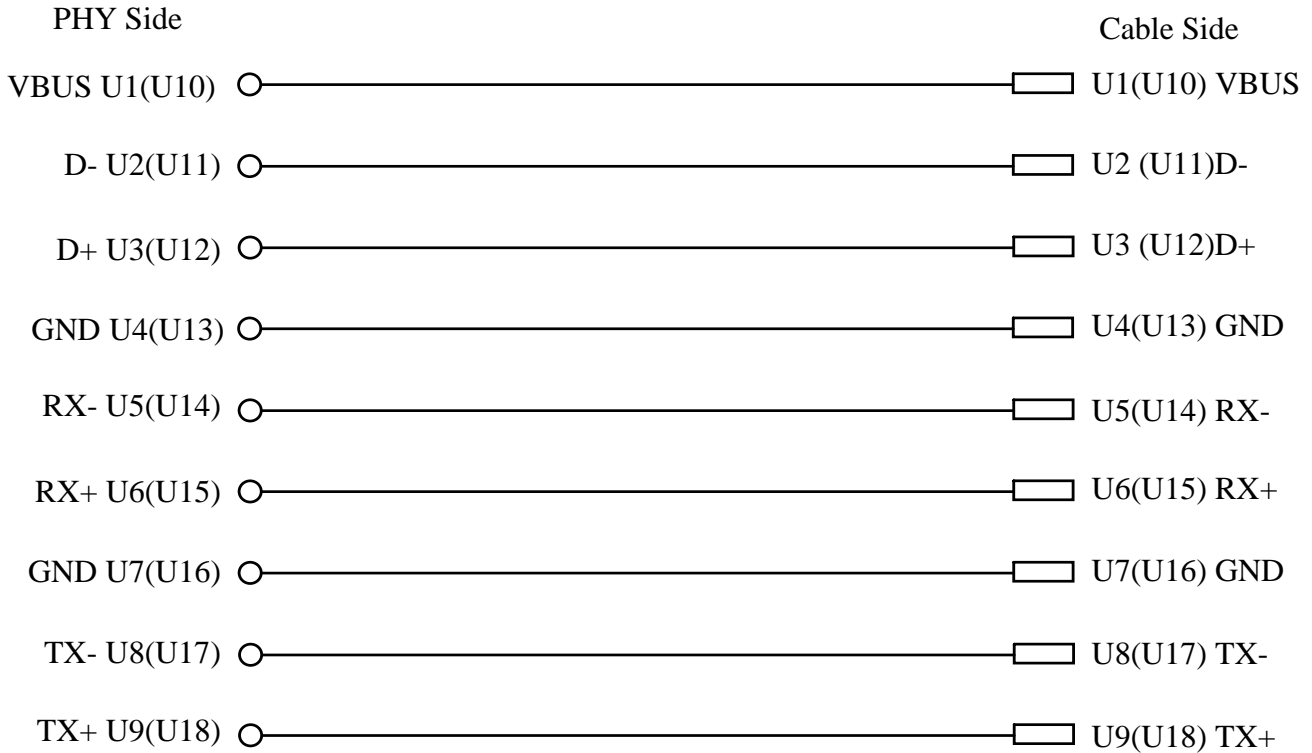

USB 3.2 GEN 1 Standard-A connector Pin Assignment

Pin Number	Signal Name	Description	Mating Sequence
U1&U10	VBUS	Power	Second
U2&U11	D-	USB 2.0 Differential pair	Third
U3&U12	D+		
U4&U13	GND	Ground for power return	Second
U5&U14	StdA_SSRX-	Super speed receiver differential pair	Last
U6&U15	StdA_SSRX+		
U7&U16	GND_DRAIN	Ground for Signal return	
U8&U17	StdA_SSTX-	Surper speed transmitter differential pair	
U9&U18	StdA_SSTX+		
Shell	Shield	Connector metal shell	First

12. ELECTRICAL CHARACTERISTICS @25°C

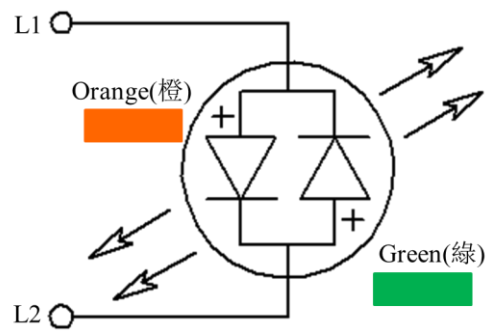
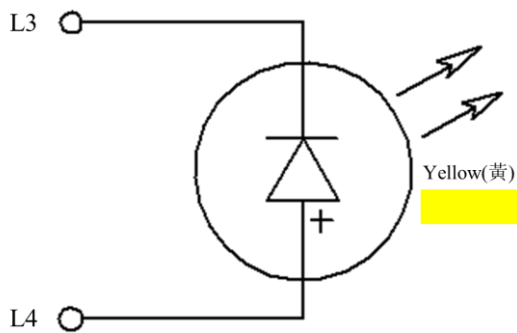
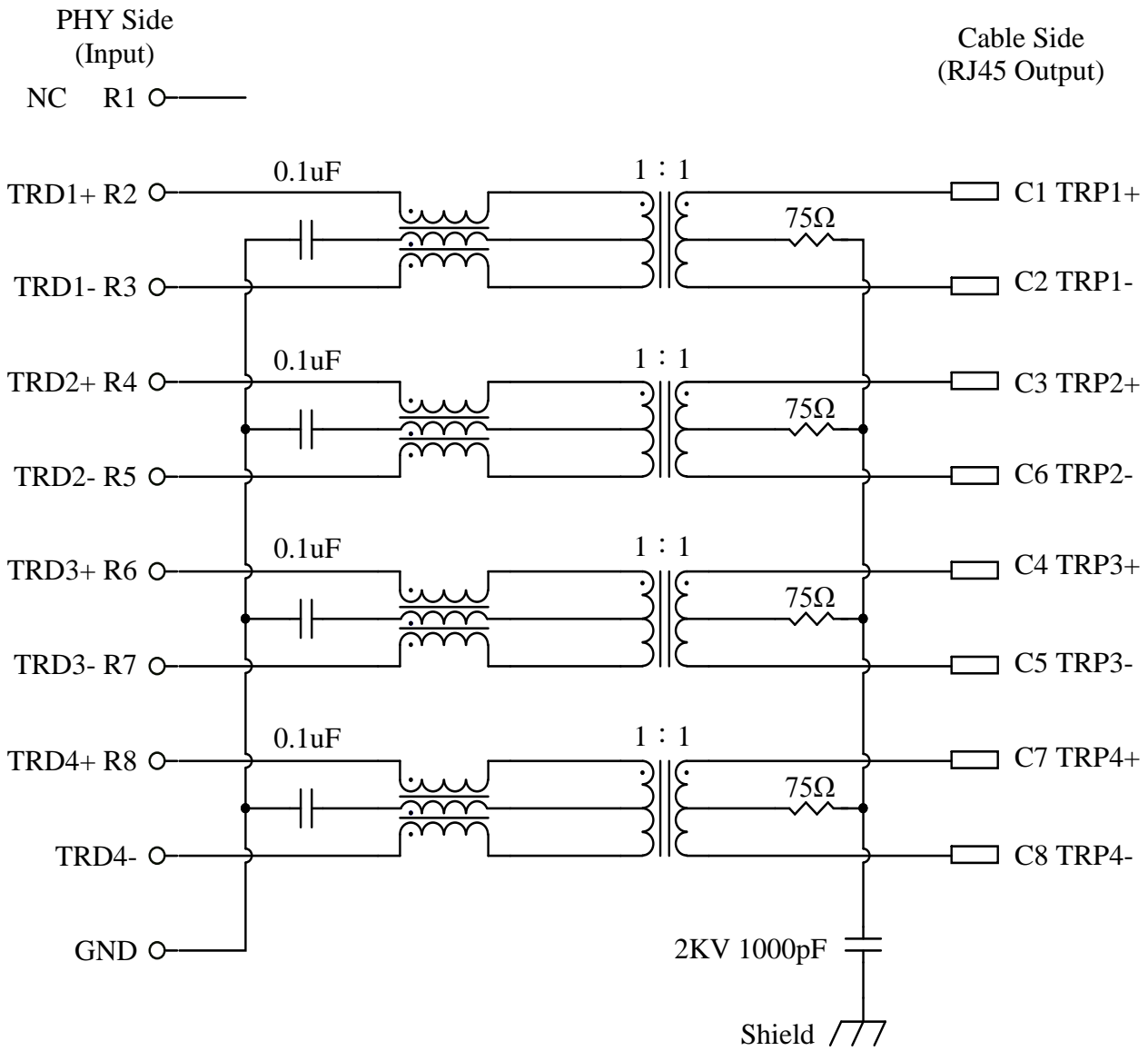

Emitting Color	$\lambda_p$ (nm)	$V_f$ @ $I_f=20mA$	$I_r$ @ $V_r=5V$
Yellow	588	1.7 ~2.6 V	10 $\mu$ A max.
Orange	605	1.7 ~2.6 V	10 $\mu$ A max.
Green	570	1.7 ~2.6 V	10 $\mu$ A max.

## Transmitter filter &amp; Receiver filter

Type : Balance low pass 100Ω impedance

Insertion loss : 1~400MHz -2.0dB(-1.4TYP) max.

Return loss :	1MHz	-20dB Min.	load 100Ω
	100MHz	-20dB Min.	load 100Ω
	200MHz	-18dB Min.	load 100Ω
	300MHz	-15dB Min.	load 100Ω
	400MHz	-10dB Min.	load 100Ω
	500MHz	-8dB Min.	load 100Ω

## Reflected CM to Diff Conversion(REF)

50MHz	-30dB Min.
100MHz	-27dB Min.
200MHz	-24dB Min.
300MHz	-22dB Min.
400MHz	-21dB Min.
500MHz	-20dB Min.

## Reflected Diff to CM Conversion(REF)

1MHz	-48dB Min.
100MHz	-35dB Min.
400MHz	-24dB Min.
500MHz	-24dB Min.

## CM to Diff Conversion (REF)

50MHz	-48dB Min.
100MHz	-42dB Min.
200MHz	-36dB Min.
300MHz	-33dB Min.
400MHz	-30dB Min.
500MHz	-28dB Min.

## CM to CM Attenuation (REF)

1MHz	-22dB Min.
500MHz	-20dB Min.
800MHz	-20dB Min.
1000MHz	-17dB Min.

## Cross Talk (REF)

1MHz	-34dB Min.
350MHz	-23dB Min.
500MHz	-23dB Min.

## Inductance (OCL) @ 25°C, 100KHz, 100mV, 8mA DC BIAS

Input(TRD1+, TRD1-); (TRD2+, TRD2-); (TRD3+, TRD3-); (TRD4+, TRD4-):160uH Min.

## HiPot Test

PHY Side(input) To Cable Side(output) : 1500Vac 60s or 2250Vdc 60s

### 13. WAVE SOLDERING TEMPERATURE PROFILE

Note :

The measuring point for the specified temperature shall be on the soldered part of the lead.

