

# APPROVAL SHEET

To :

Customer P/N :

UDE P/N : RU4-ZZ-0084

Description : RJ45 Tab up over USB 2.0 stack

Through Hole

10/100/1000 Base-T

Contact Area : 30 $\mu$ " Min. Gold

LED : L-Green/Orange; R-Green



Spec No.  
RU419013-00

Update Date  
2019/3/26

Revision  
A

Approved	Checked	Prepared



湧德電子 股份有限公司  
UDE Corp.

桃園市(33852) 蘆竹區內溪路 68 巷13號

No.13, Ln. 68, Neixi Rd., Luzhu Dist., Taoyuan City (33852), Taiwan

TEL: 886-3-3242000 FAX: 886-3-3246611

<http://www.ude-corp.com/>



1. MECHANICAL DIMENSION

Product Dimension

Unit:mm	General Tolerance :	X.X : ± 0.38
		X.XX : ± 0.20

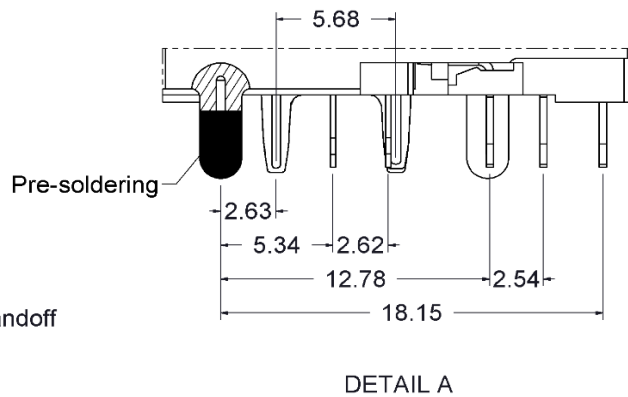
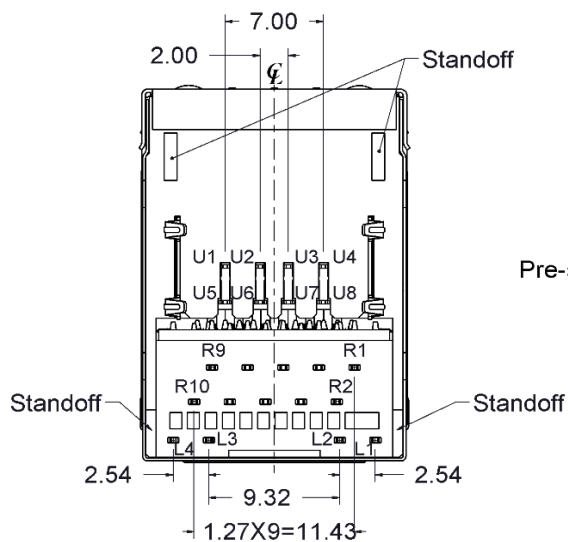
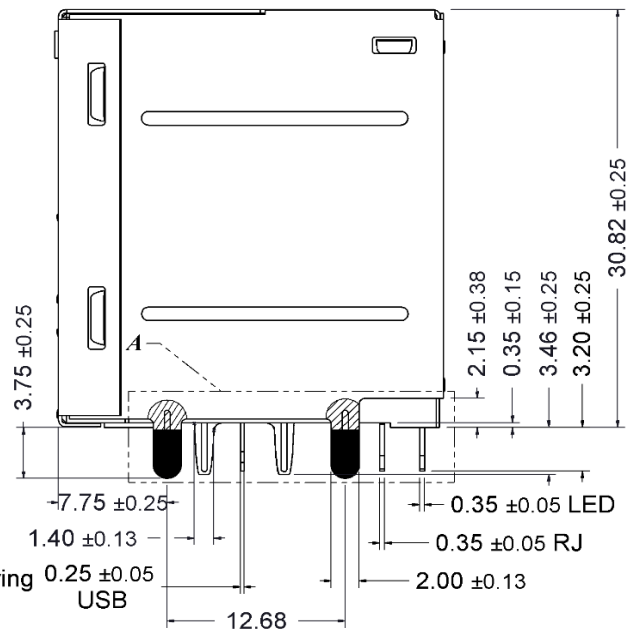
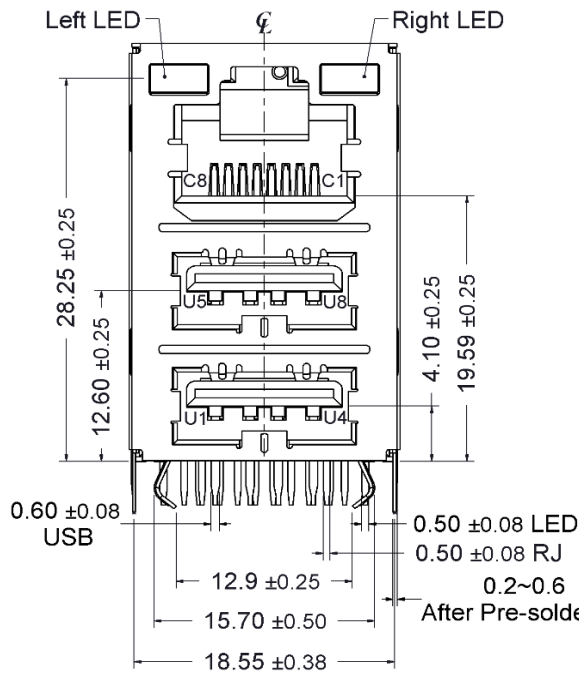
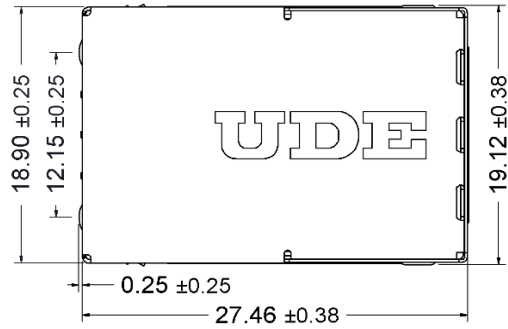
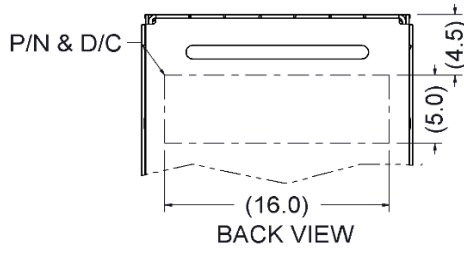

Recommended PCB Layout. Component side of board

All dimension units are "mm".

All dimension tolerances are ±0.05mm unless otherwise specified.

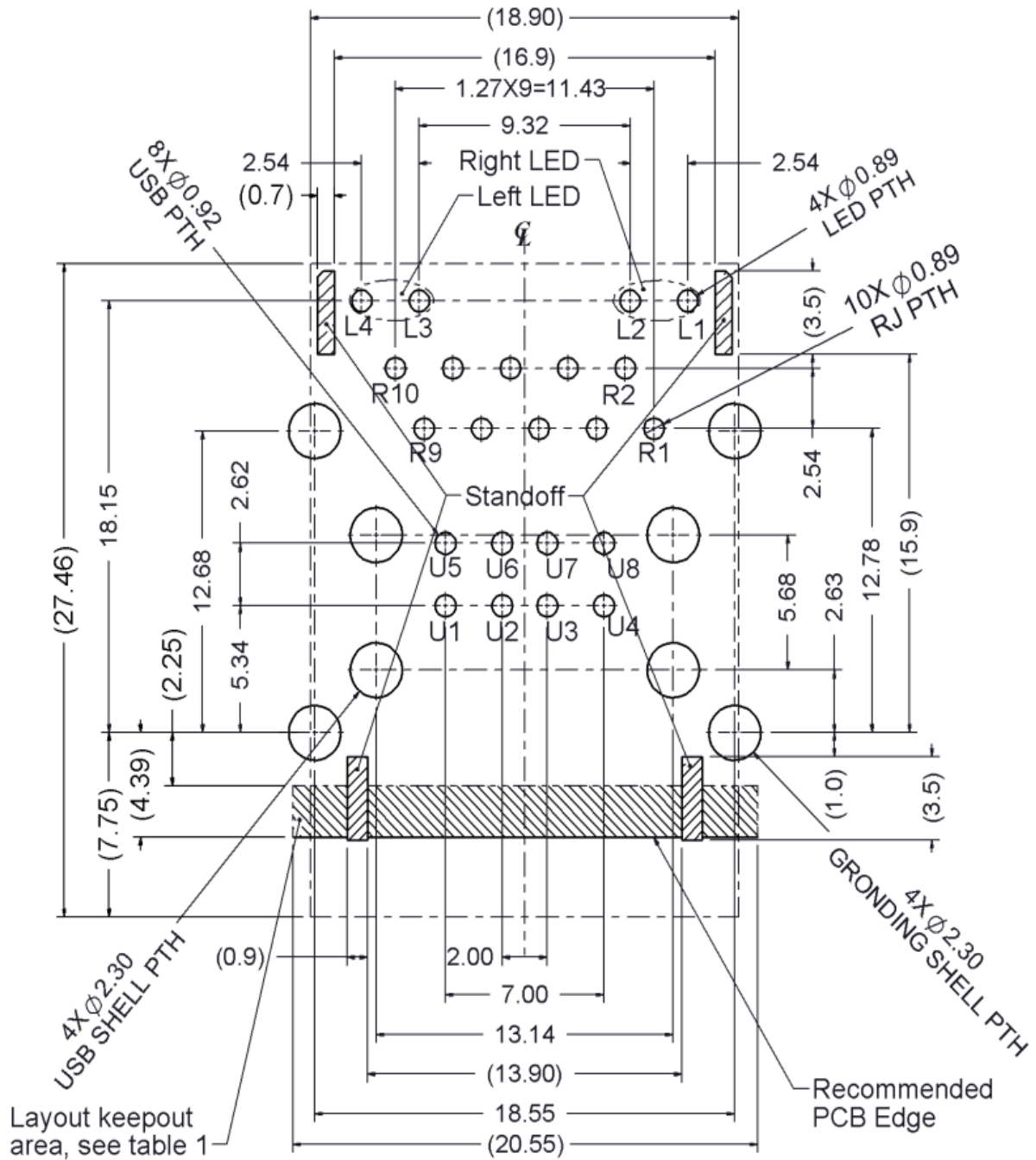
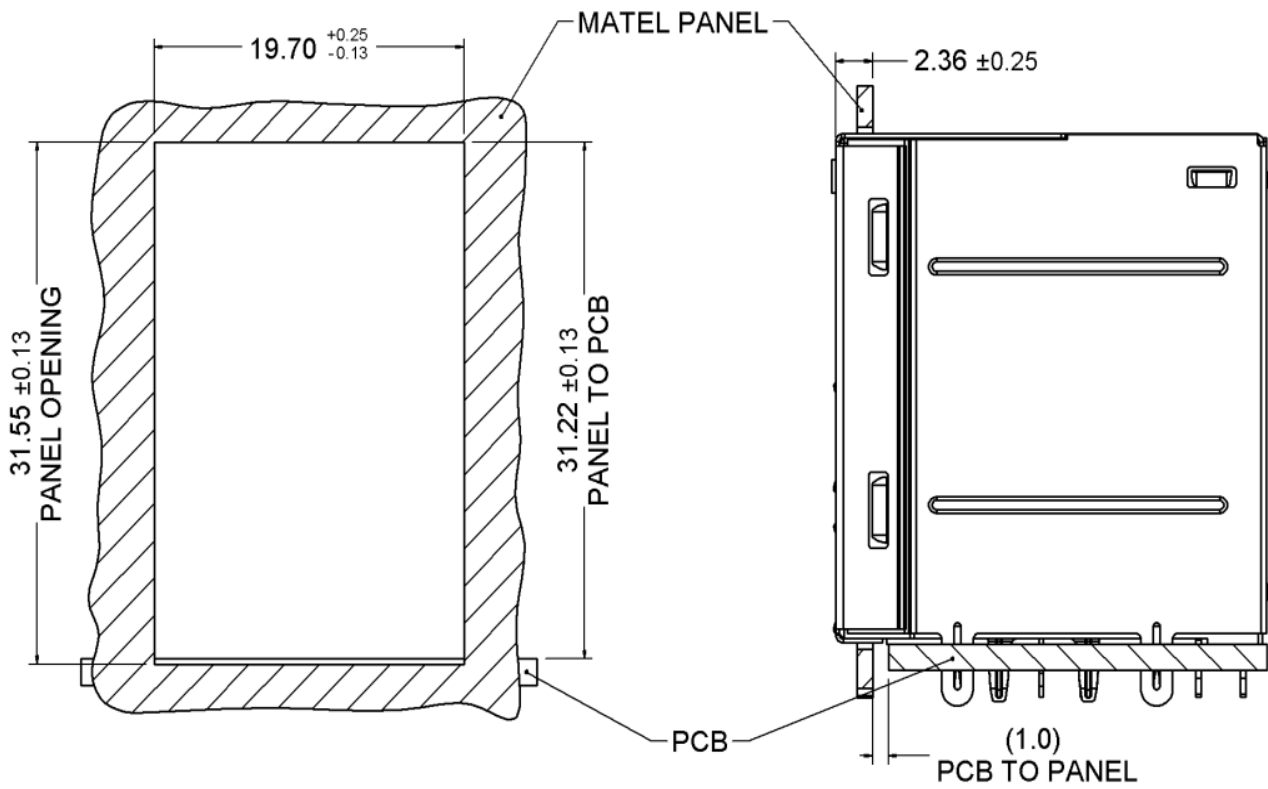

Table1

Layout Layer	Trace	component	Grounding	Test Point	Via Hole	PTH	NPTH
Component side	X	X	O	X	X	X	O
Inner layer	O	NA	O	NA	O	X	O
Bottom side	O	O	O	O	O	X	O

X--Forbid; O--OK; NA--Not Applicable.

Recommended Panel cutout



2. Packing Information

40 pcs finished goods per tray

5 trays(200 pcs finished goods) per inner box

4 Inner boxes(800 pcs finished goods) per master carton

### 3. Standard RJ45 Plug Specification

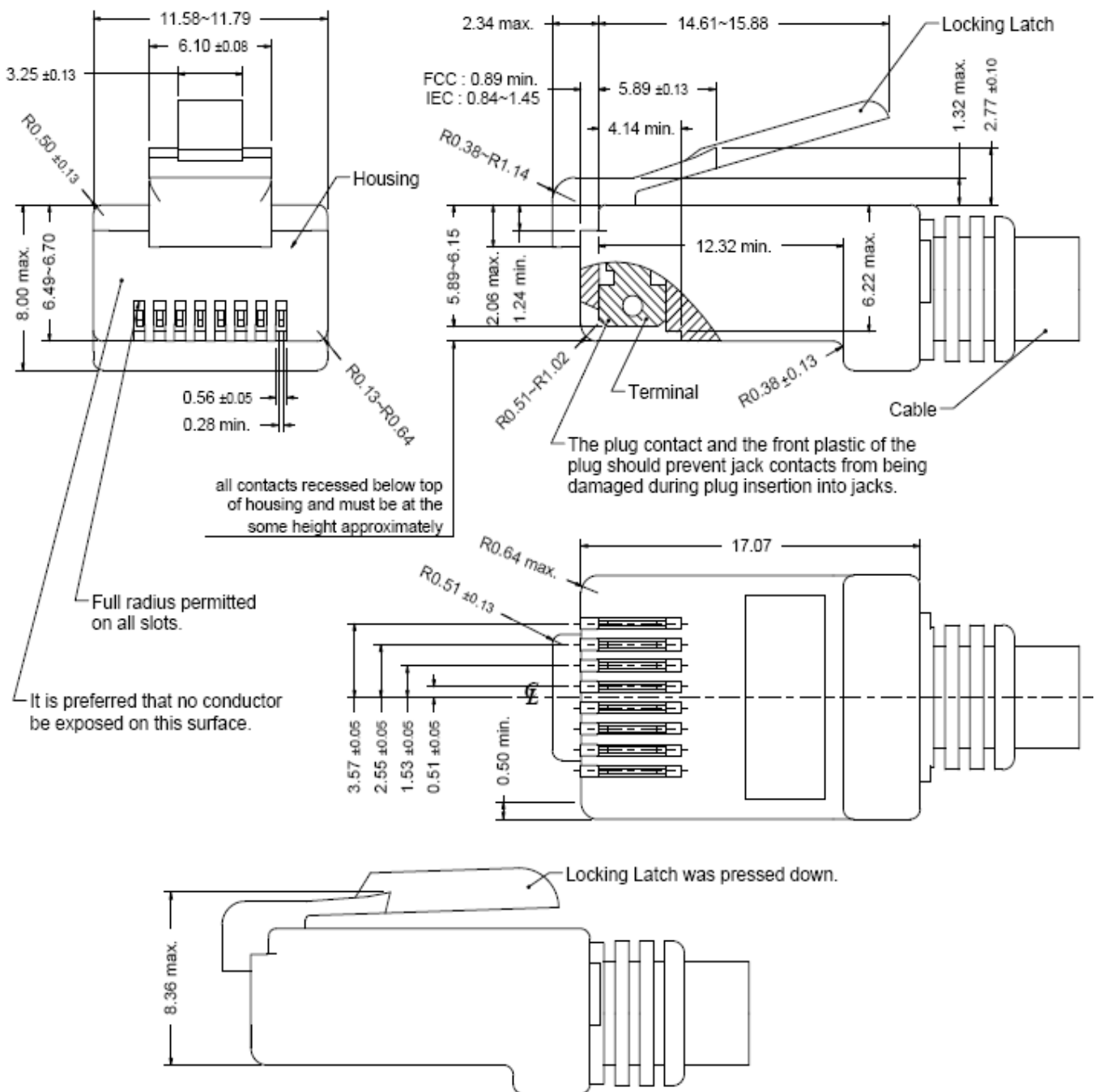

- All dimensions follow :  
FCC subpart F, 68,500, Figure (C)(2)(i) & (C)(2)(ii) & (C)(3)(i)  
IEC 60603-7
- All plugs must be meeting the requirements of plug Go & No-Go gauge.  
Gauge follow : FCC subpart F, 68,500, Figure (C)(4)(i) & (C)(5)(i)
- There must be no damage to Housing and Locking Latch.
- There must be no nicks and cuts in cable.
- Durability : 750 cycles generally

### 4. Standard USB 2.0 Plug Specification

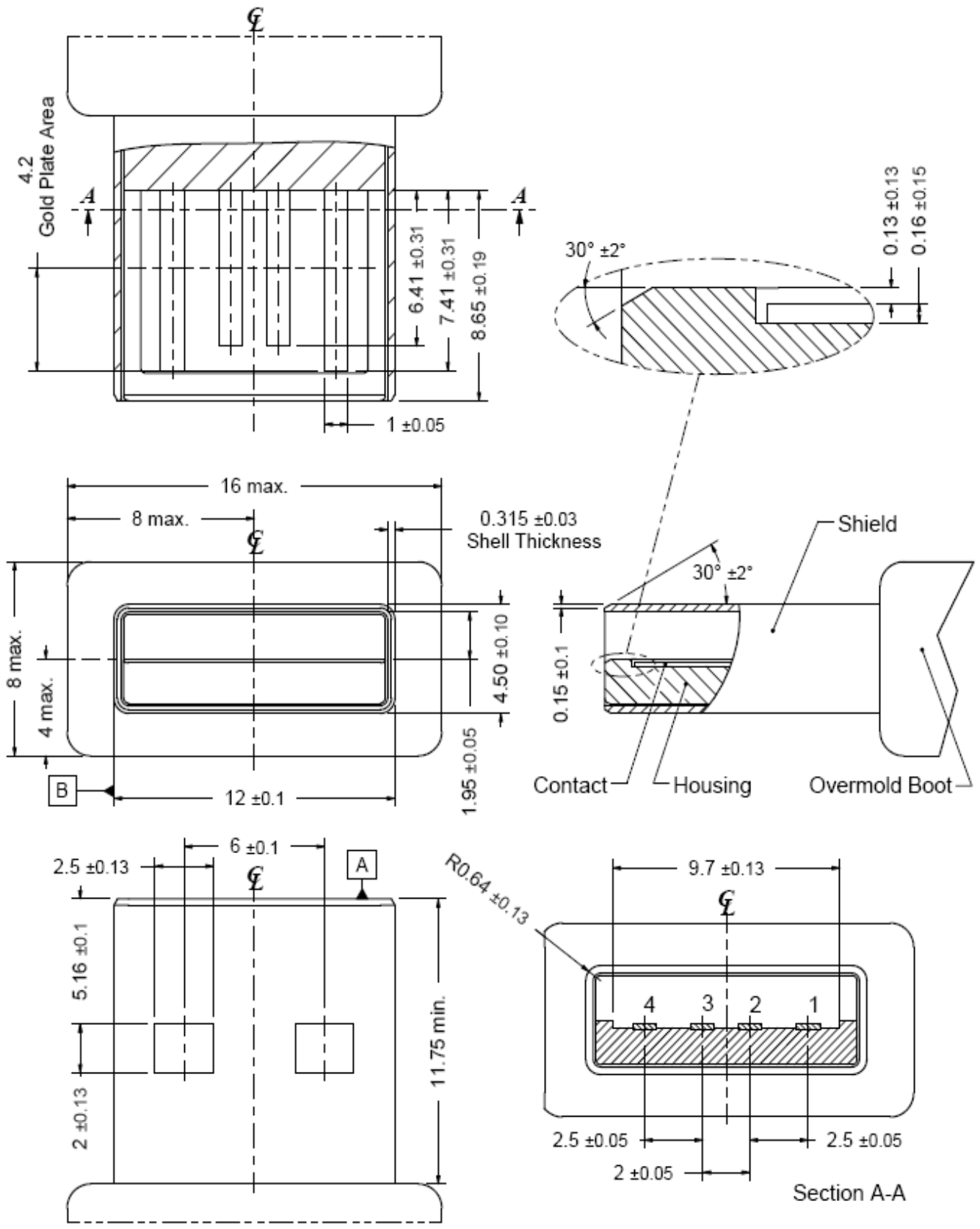

- All dimensions follow : Universal Series Bus Specification 2.0 (April 27,2000)

Figure 6-9. USB Series A Plug Interface Drawing

## 5. REQUIREMENTS

### Design and Construction

Product shall be of design, construction and physical dimensions specified on applicable.

### Material

Terminal Parts (Underplating : 50 $\mu$ " min. Nickel overall)

RJ Terminal : Phosphor Bronze, Thickness=0.30mm

Finish Contact Area : 30 $\mu$ " min. Gold

USB Terminal : Phosphor Bronze, Thickness=0.25mm

Finish Contact Area : 30 $\mu$ " min. Gold

Solder Tail : 100 $\mu$ " min. Bright Tin

Input Terminal : Brass, Thickness=0.35mm

Finish : 100 $\mu$ " min. Bright Tin

Case Terminal : CP Wire, Diameter=0.40mm

Finish : 100 $\mu$ " min. Bright Tin

Plastic Parts <UL94V-0>

Housing : PBT, Black

Case : PF2A5-151J(b), Black

Spacer : PBT, Black

Shield Parts

Front Shield : stainless steel, Thickness=0.25mm, unplating

Back Shield : stainless steel, Thickness=0.20mm, Pre-soldering

USB Kink : Brass, Thickness=0.25mm

Finish : 100 $\mu$ " min. Tin over 30 $\mu$ " min. Nickel overall

## 6. Operating and Storage Temperature

Operating Temperature : 0°C to +70°C

Storage Temperature : -40°C to +85°C

## 7. RJ45 specifications

Insulation Resistance : 500MΩ min.

Insertion force with the latch depressed : 20N max.

Removal force with the latch depressed : 20N max.

Locking Force of Plug Latch : 50N min. @ 60+/-5 sec.

Durability : 2500 cycles

## 8. USB 2.0 specifications

Insulation Resistance : 1000MΩ min.

Dielectric Withstanding Voltage : 500Vac @1min.

Insertion force : 35N max.

Removal force : 10N min.

Durability : 1500 cycles

## 9. Performance and Test Description

Product is designed to meet electrical, mechanical and environmental performance requirements specified in below table.

All tests are performed at ambient environmental conditions per MIL-STD-1344A and EIA-364 unless otherwise specified.

## 10 Packaging and Packing

All parts shall be packaged and packed to protect against physical damage, corrosion and deterioration during shipment and storage.

11. USB 2.0 Standard-A Schematic

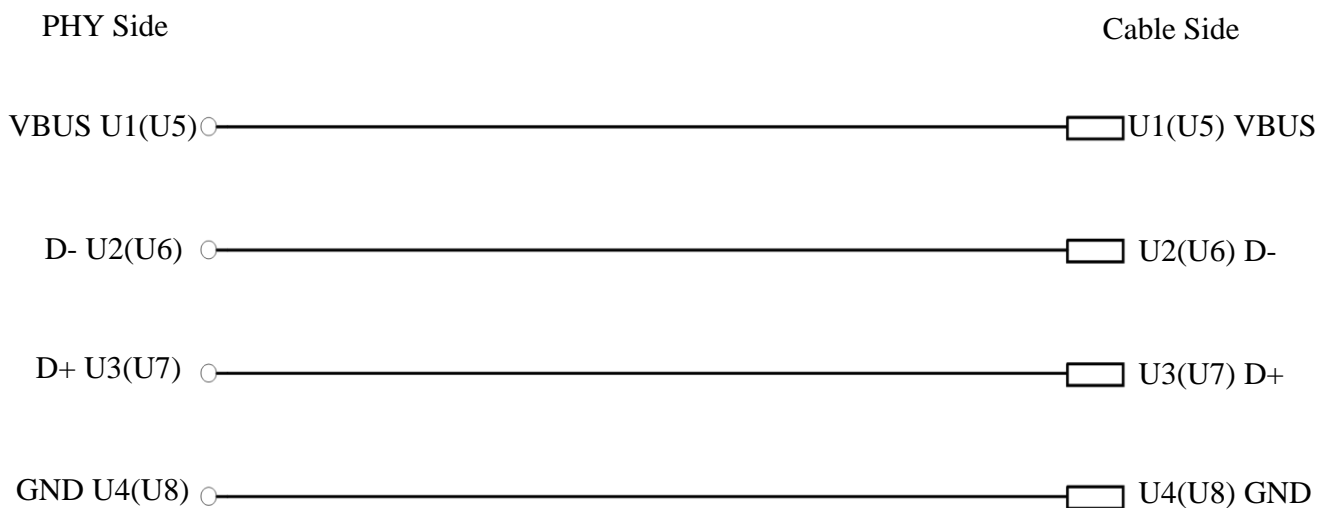

USB 2.0 Standard-A Pin Assignment

Pin Number	Signal Name	Description	Mating Sequence
U1&U5	VBUS	Power	Second
U2&U6	D-	USB 2.0 Differential pair	Third
U3&U7	D+		
U4&U8	GND	Ground for power return	Second
Shell	Shield	Connector metal shell	First

12. ELECTRICAL CHARACTERISTICS @25°C

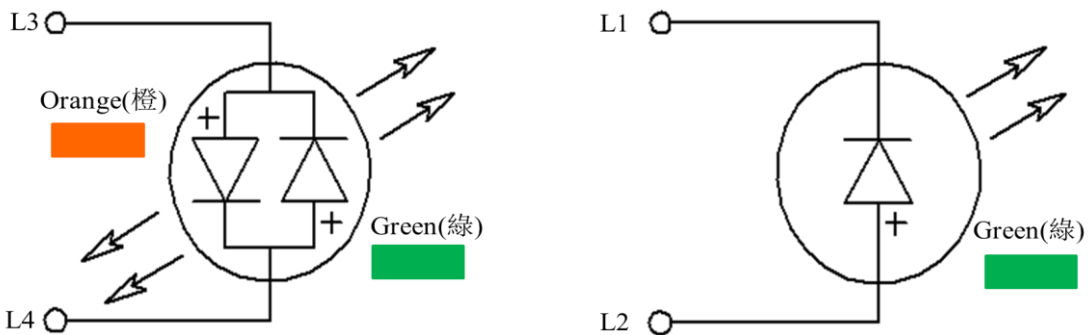
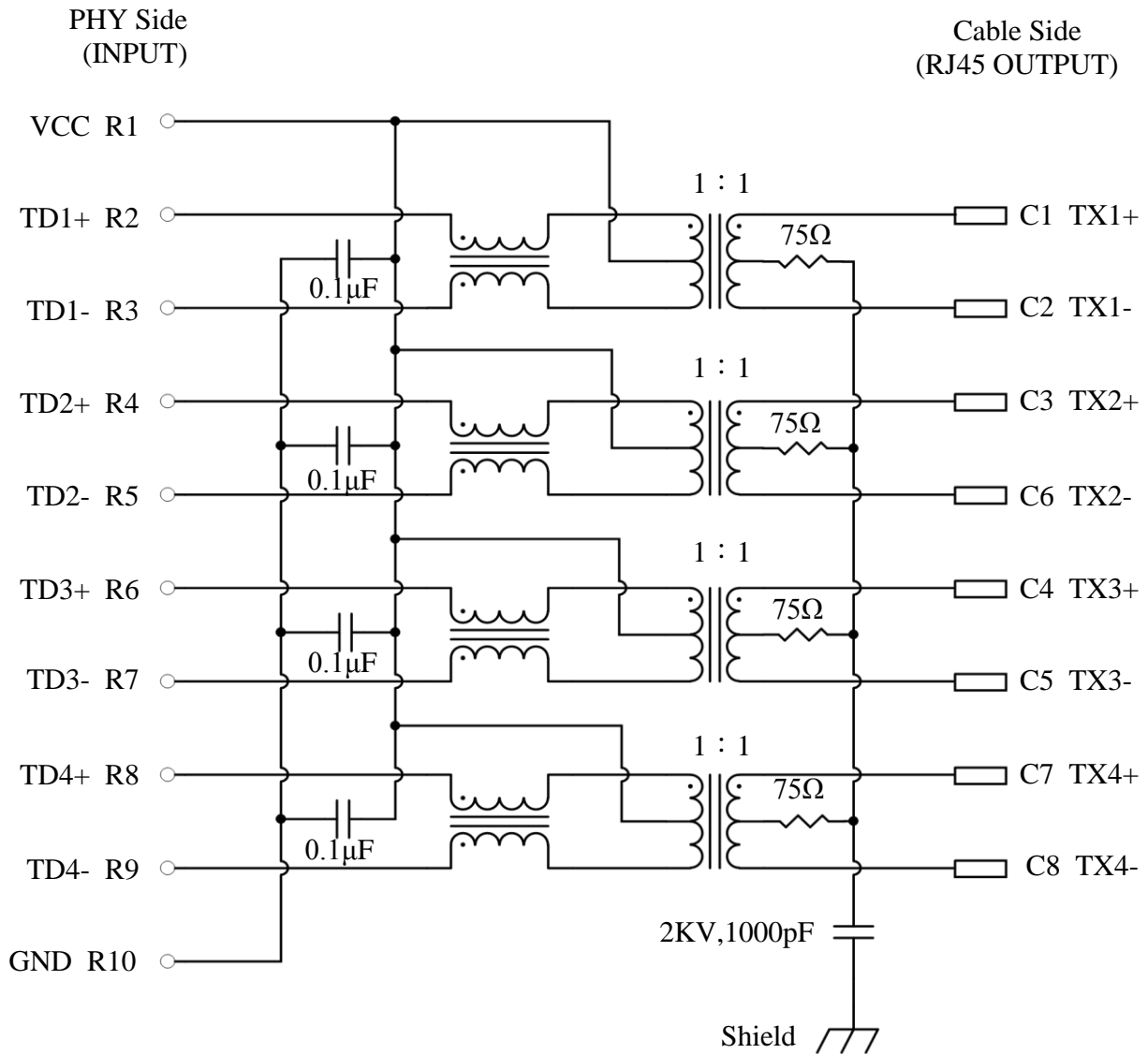

Emitting Color	$\lambda_p$ (nm)	$V_f$ @ $I_f=20mA$	$I_r$ @ $V_r=5V$
Green	570	1.7 ~2.6 V	10 $\mu$ A max.
Orange	605	1.7 ~2.6 V	10 $\mu$ A max.

## Transmitter filter &amp; Receiver filter

Type : Balance low pass 100Ω impedance

Insertion loss : 1~100MHz -1.0dB max.

Return loss :	1~30MHz	-18dB min.	load 100Ω
	30~60MHz	-16dB min.	load 100Ω
	60~80MHz	-12dB min.	load 100Ω
	80~100MHz	-10dB min.	load 100Ω

## Common Mode Rejection

@1~100 MHz -30dB min.

## Cross Talk

@ 1~100MHz -30dB min.

## Inductance (OCL) @ 100KHz, 0.1V, 8mA DC BIAS

Input(TD1+,TD1-); (TD2+,TD2-); (TD3+,TD3-); (TD4+,TD4-) : 350 μH min.

## HiPot Test

PHY Side(input) To Cable Side(output) : 1500Vac 60s or 2250Vdc 60s

### 13. WAVE SOLDERING TEMPERATURE PROFILE

Note :

The measuring point for the specified temperature shall be on the soldered part of the lead.

