

APPROVAL SHEET

To :

Customer P/N :

UDE P/N : L22T003-3

Description : 2.5G Base-T

Single Port LAN Filter

Meet IEEE802.3 bt type3 standard



RoHS **HF** Halogen Free

Spec No.
LZ0043-00

Update Date
2020/12/1

Revision
E

Approved	Checked	Prepared



湧德電子 股份有限公司
UDE Corp.

桃園市(33852) 蘆竹區內溪路 68 巷13號
No.13, Ln. 68, Neixi Rd., Luzhu Dist., Taoyuan City (33852), Taiwan
TEL: 886-3-3242000 FAX: 886-3-3246611
<http://www.ude-corp.com/>

1. MECHANICAL DIMENSION

1.1 Product Dimension

General Tolerance : X.X : ± 0.25
 X.XX : ± 0.13

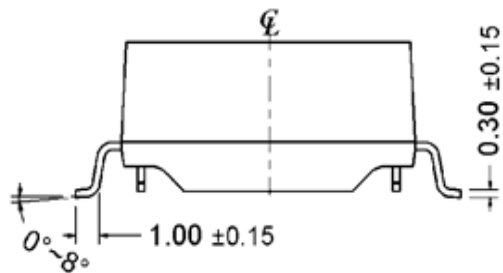
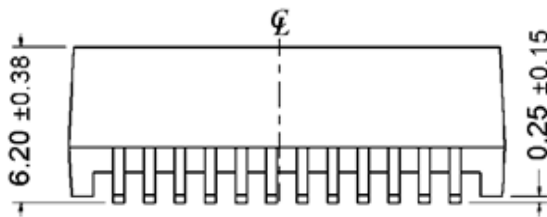
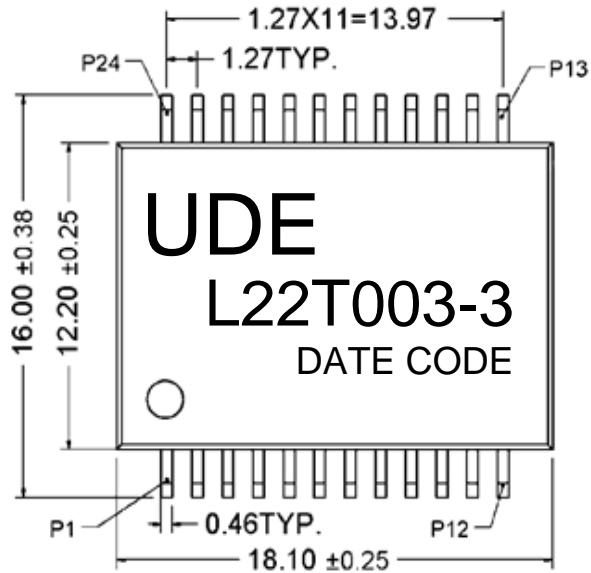

1.2 Recommended PCB Layout

Component Side of Board

All dimension tolerance are $\pm 0.08\text{mm}$ unless otherwise specified

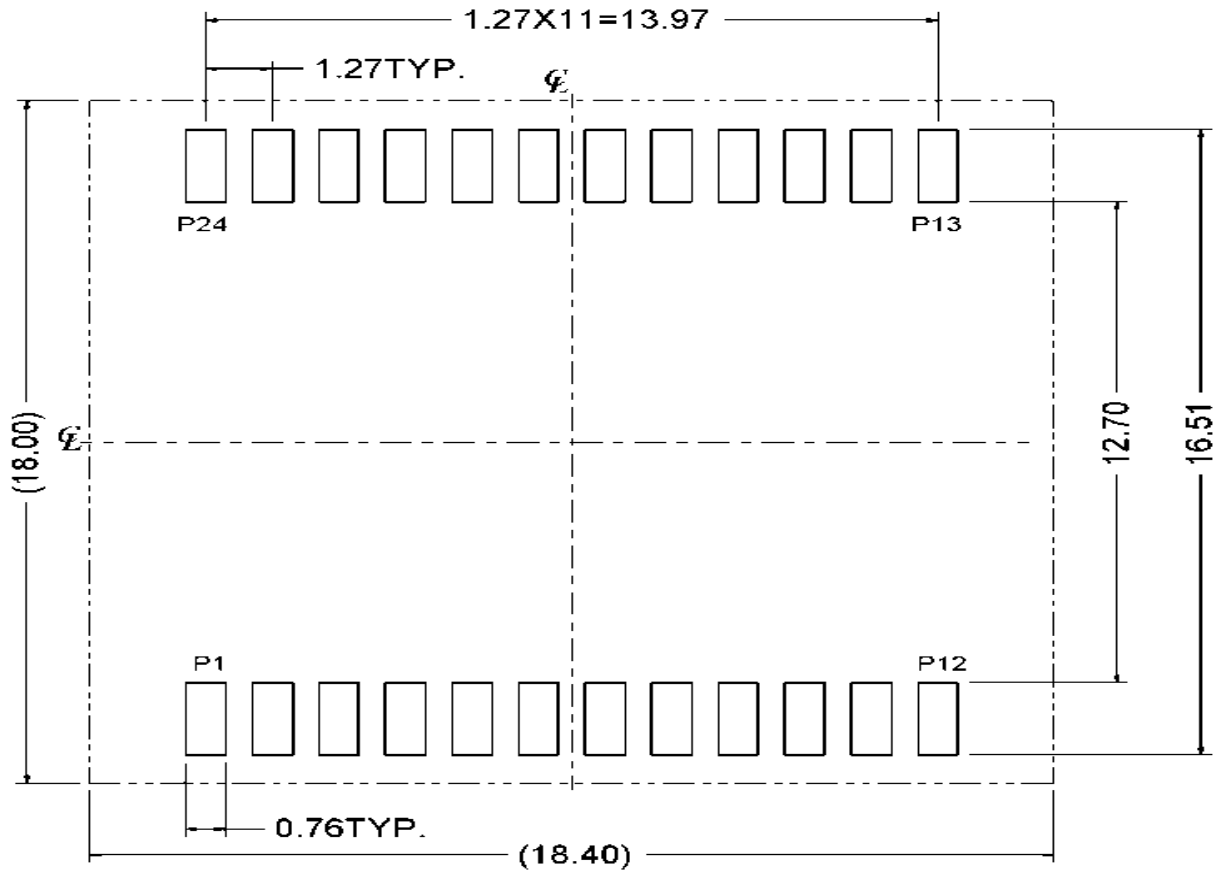

1.3 Order Information

L 2 2 I 003 - 3
 A B C D E F

- A、 Filter
- B、 SMD
- C、 24PIN
- D、 Operating Temperature : -40°C to $+85^{\circ}\text{C}$
- E、 Product Numbering
- F、 PoE Plus

2. FEATURES

- 2.1 Designed for Ethernet 2.5G Base-T, Single port applications.
- 2.2 Supports 4 pairs of category 5 UTP cable.
- 2.3 Cable interface for isolation and low common mode emissions.
- 2.4 Design to meet IEEE 802.3bt type3 with 720mA balanced current.
- 2.5 Compliant with RoHS&Halogen Free requirements.

2.6 Operating and Storage Temperature

Operating Temperature : -40°C to +85°C

Storage Temperature : -40°C to +85°C

2.7 Packing Information

400 pcs finished goods per reel

3 reels(1200 pcs finished goods) per inner box

2 Inner boxes(2400 pcs finished goods) per master carton

3. ELECTRICAL CHARACTERISTICS

3.1 Schematic

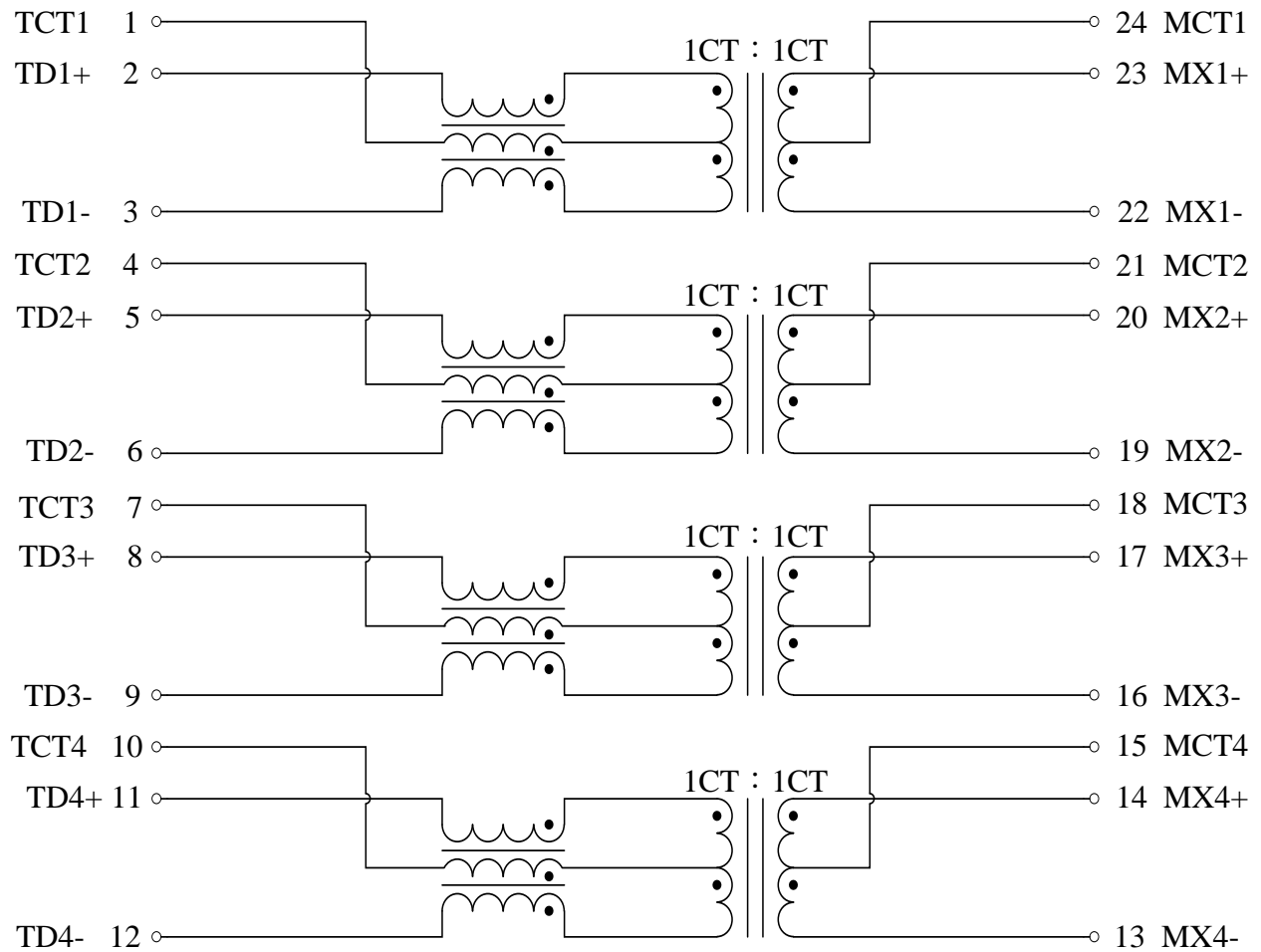

3.2 Electrical Specifications @25°C

Type : Balance low pass 100Ω impedance

3.2.1 Insertion loss :

1-50MHz -0.5 dB Max

50-125MHz -1.0 dB Max

3.2.2 Return loss :

1~40MHz -20 dB Min load 100Ω

40-200MHz $-20+15*\log(\text{Freq MHz}/40\text{MHz})$ dB Min load 100Ω

3.2.3 Reflected CM to Diff Conversion(REF)

1MHZ -30 dB Min

50MHZ -30 dB Min

100MHZ -27 dB Min

200MHZ -24 dB Min

3.2.4 CM to DM Conversion(REF)

1-125MHZ -35 dB Min

3.2.5 Reflected Diff to CM Conversion(REF)

1-10MHZ -48 dB Min

10-200MHz $-48+19*\log(\text{Freq MHz}/10\text{MHz})$ dB Min

3.2.6 CM to CM Attenuation (REF)

1-200MHZ -25 dB Min

3.2.7 Cross Talk (REF)

1-125 MHz -30 dB Min

125-200 MHz -25 dB Min

3.3 Inductance

@ 100KHz, 0.1V, 11mA DC BIAS 120uHMin

3.4 HiPot Test

@ 1500 Vrms

3.5 Turns Ratio

@ 1:1±5%

4. IR REFLOW TEMPERATURE PROFILE

Step#	Profile Feature	Condition/Duration
Step1	Ramp-up rate	3°C/sec max
Step2	Preheat : 150~200°C	Ta-Tb : 60-180sec
Step3	Ramp-up rate (TL to Tp)	3°C/sec max
	Temperature maintained above 217°C (TL)	tl : 60-150sec
Step4	Measured Peak temperature of pin (Tp) Set Reflow Peak Temp.	260°C
	The Time of Actual Peak temperature	20-40sec
Step5	Ramp-down rate	6°C/sec max
Note1	All temperatures refer to topside of the package, measured on the package body surface	
Note2	Time 25°C to peak temperature : 8 minutes max.	
Note3	It is not allowed to make a forced cooling in temperature falling range.	
Note4	The applicable condition refer to IPC/JEDEC J-STD-020D standard	

Table 1 Pb-Free Process-Classification Temperatures (Tp)

Package Thickness	Volume mm3 <350	Volume mm3 350-2000	Volume mm3 >2000
<1.6mm	260°C	260°C	260°C
1.6mm-2.5mm	260°C	260°C	260°C
>2.5mm	260°C	260°C	260°C

