

APPROVAL SHEET

To :

Customer P/N :

UDE P/N : L22N001-2

Description : 1000 Base -T

Single Port LAN Filter

Meet IEEE802.3 af standard



Halogen
Free

Spec No.
LZ0096-00

Update Date
2020/4/11

Revision
D

Approved	Checked	Prepared



湧德電子 股份有限公司
UDE Corp.

桃園市(33852) 蘆竹區內溪路 68 巷13號

No.13, Ln. 68, Neixi Rd., Luzhu Dist., Taoyuan City (33852), Taiwan

TEL: 886-3-3242000 FAX: 886-3-3246611

<http://www.ude-corp.com/>

1. MECHANICAL DIMENSION

1.1 Product Dimension

General Tolerance : X.X : ± 0.25
X.XX : ± 0.13

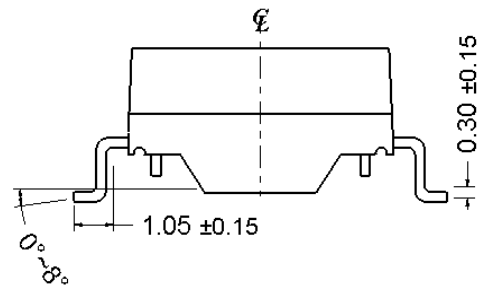
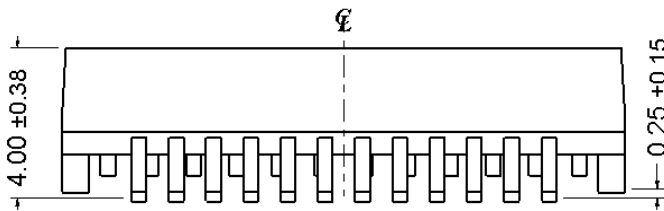
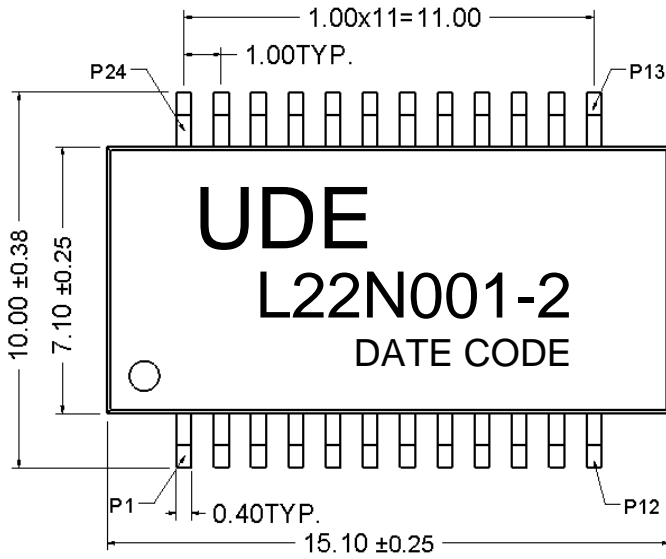

1.2 Recommended PCB Layout

Component Side of Board

All dimension tolerances are $\pm 0.08\text{mm}$ unless otherwise specified

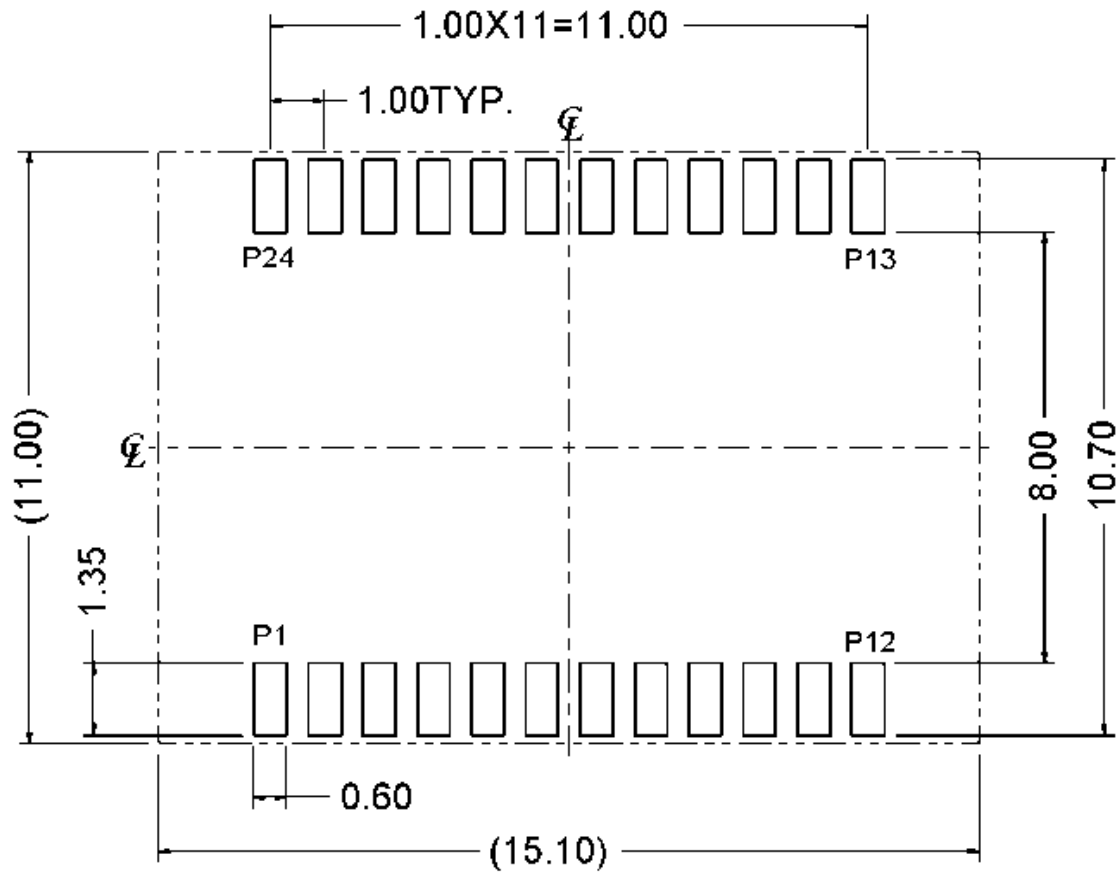

1.3 Order Information

L 2 2 N 001 - 2
 A B C D E F

- A、 Filter
- B、 SMD
- C、 24PIN
- D、 Normal
- E、 Product Numbering
- F、 PoE

2. SPECIFICATION

- 2.1 Designed for Ethernet 1000 Base-T,Single port applications.
- 2.2 Supports 4 pairs of category 5 UTP cable.
- 2.3 Cable interface for isolation and low common mode emissions.
- 2.4 Design to meet IEEE 802.3af with 350mA balanced current.
- 2.5 Compliance with RoHS&Halogen Free requirements.
- 2.6 Operating and Storage Temperature
 - Operating Temperature : 0°C to +70°C
 - Storage Temperature : -25°C to +105°C
- 2.7 Packing Information
 - 800 pcs finished goods per reel
 - 3 reels(2400 pcs finished goods) per inner box
 - 2 Inner boxes(4800 pcs finished goods) per master carton

3. ELECTRICAL CHARACTERISTICS

3.1 Schematic

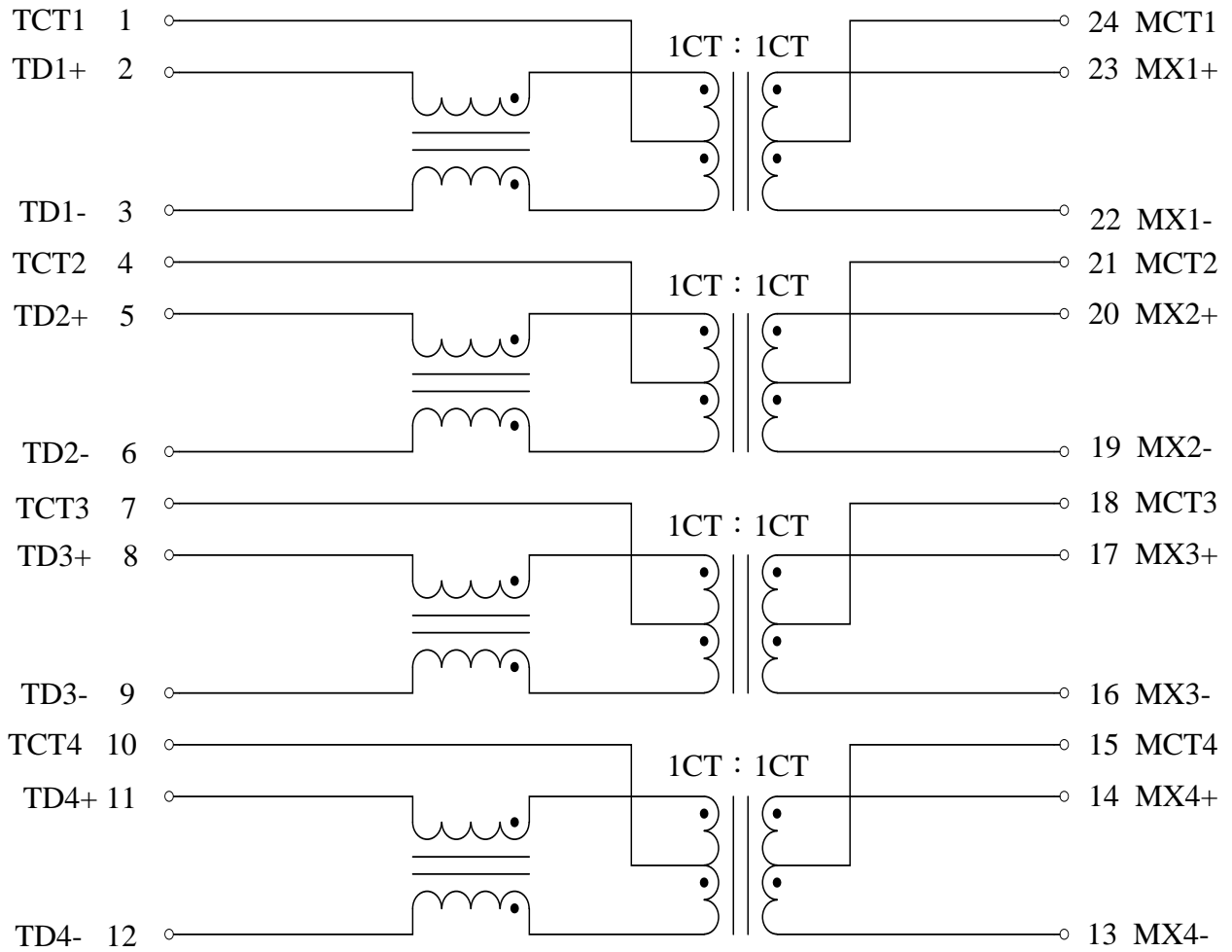

3.2 Electrical Specifications @25°C

Type : Balance low pass 100Ω impedance

Insertion loss : 1~100 MHz -1.0dB max.

Return loss : 1~30 MHz -18dB min. load 100Ω

30~60MHz -14dB min. load 100Ω

60~80MHz -12dB min. load 100Ω

80~100MHz -10dB min. load 100Ω

3.3 DCMR

@ 30 MHz -40dB min.

@ 60 MHz -35dB min.

@ 100 MHz -30dB min.

3.4 Cross Talk

@ 30 MHz -40dB min.

@60 MHz -35dB min.

@ 100 MHz -30dB min.

3.5 Inductance

@ 100KHz, 0.1V, 8mA DC BIAS 350uHMin

3.6 HiPot Test

@ 1500 Vrms

3.7 Turns Ratio

@ 1:1±5%

4. IR REFLOW TEMPERATURE PROFILE

Step#	Profile Feature	Condition/Duration
Step1	Ramp-up rate	3°C/sec max
Step2	Preheat : 150~200°C	Ta-Tb : 60-180sec
Step3	Ramp-up rate (TL to Tp)	3°C/sec max
	Temperature maintained above 217°C (TL)	tl : 60-150sec
Step4	Measured Peak temperature of pin (Tp) Set Reflow Peak Temp.	260°C
	The Time of Actual Peak temperature	20-40sec
Step5	Ramp-down rate	6°C/sec max
Note1	All temperatures refer to topside of the package, measured on the package body surface	
Note2	Time 25°C to peak temperature : 8 minutes max.	
Note3	It is not allowed to make a forced cooling in temperature falling range.	
Note4	The applicable condition refer to IPC/JEDEC J-STD-020D standard	

Table 1 Pb-Free Process-Classification Temperatures (Tp)

Package Thickness	Volume mm ³ <350	Volume mm ³ 350-2000	Volume mm ³ >2000
<1.6mm	260°C	260°C	260°C
1.6mm-2.5mm	260°C	260°C	260°C
>2.5mm	260°C	260°C	260°C

