

APPROVAL SHEET

To :

Customer P/N :

UDE P/N : L22B005-0

Description : 10G Base -T
Single Port LAN Filter



Halogen
Free

Spec No.
LZ0190-00

Update Date
2020/10/14

Revision
C

Approved	Checked	Prepared



湧德電子 股份有限公司
UDE Corp.

桃園市(33852) 蘆竹區內溪路 68 巷13號
No.13, Ln. 68, Neixi Rd., Luzhu Dist., Taoyuan City (33852), Taiwan
TEL: 886-3-3242000 FAX: 886-3-3246611
<http://www.ude-corp.com/>

1. MECHANICAL DIMENSION

1.1 Product Dimension (Unit mm)

General Tolerance : X.X : ± 0.25
X.XX : ± 0.13

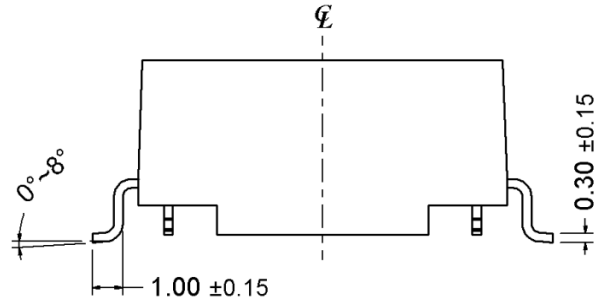
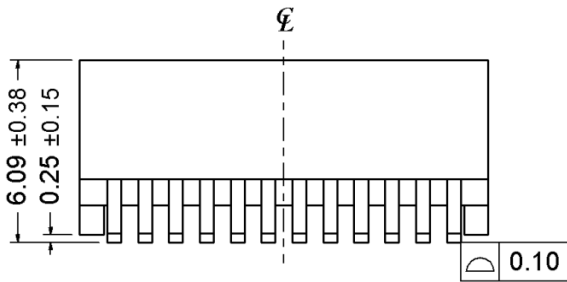
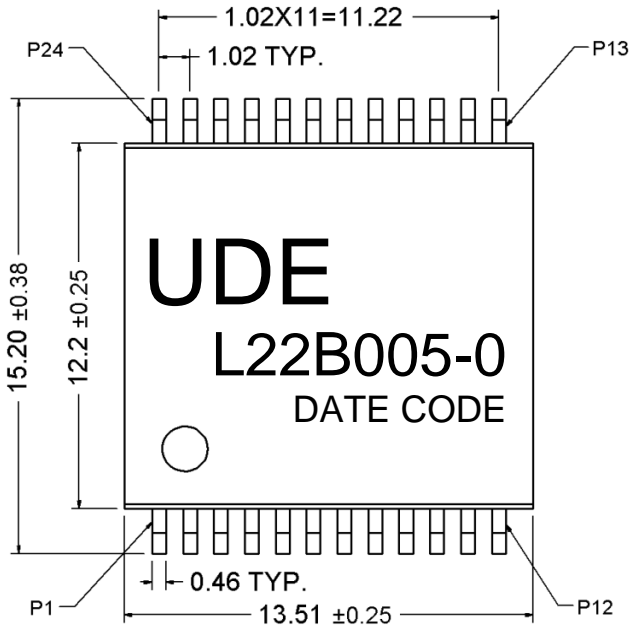

1.2 Recommended PCB Layout (Unit mm)

Component Side of Board

All dimension tolerance are ± 0.08 mm unless otherwise specified

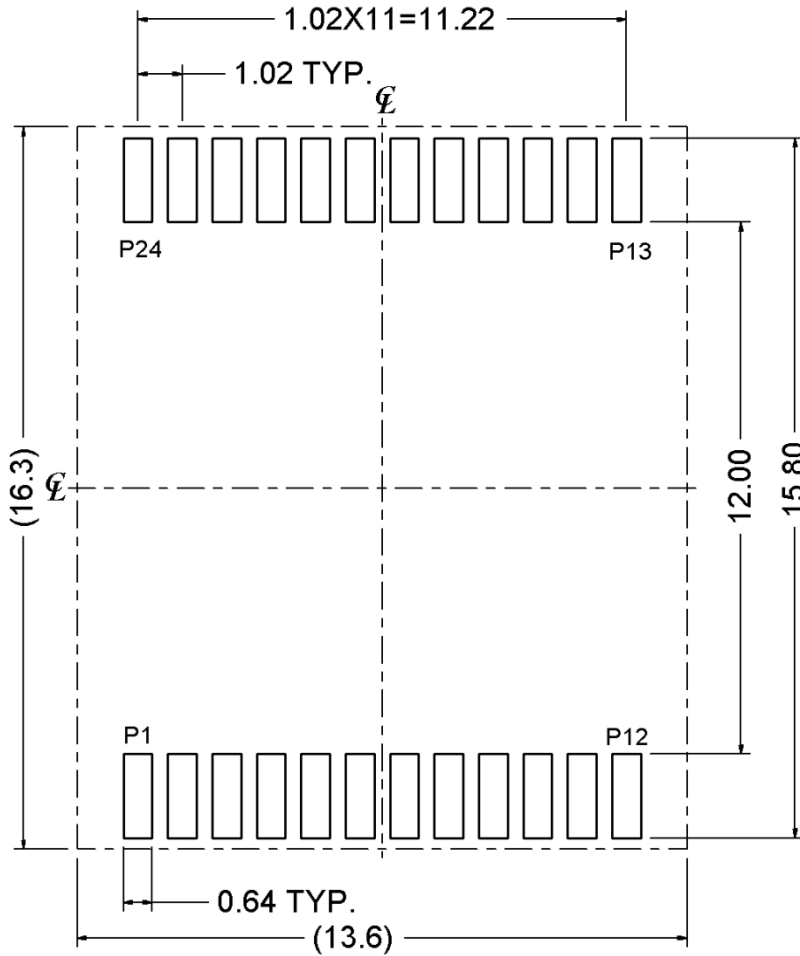

1.3 Order Information

L 2 2 B 005 - 0
 A B C D E F

- A、Filter
- B、SMD
- C、24PIN
- D、Operating Temperature :-40°C to +85°C
- E、Product Numbering
- F、Normal

2. SPECIFICATION

2.1 Designed for Ethernet 10G Base-T,full Single port applications.

2.2 Supports 4 pairs of category 6A or greater cable.

2.3 Cable interface for isolation and low common mode emissions.

2.4 Design to meet IEEE 802.3an Specification.

2.5 Compliant with Halogen Free&RoHS requirements.

2.6 Operating and Storage Temperature

Operating Temperature : -40°C to +85°C

Storage Temperature : -40°C to +85°C

2.7 Packing Information

500 pcs finished goods per reel

3 reels(1500 pcs finished goods) per inner box

2 Inner boxes(3000 pcs finished goods) per master carton

3. ELECTRICAL CHARACTERISTICS

3.1 Schematic

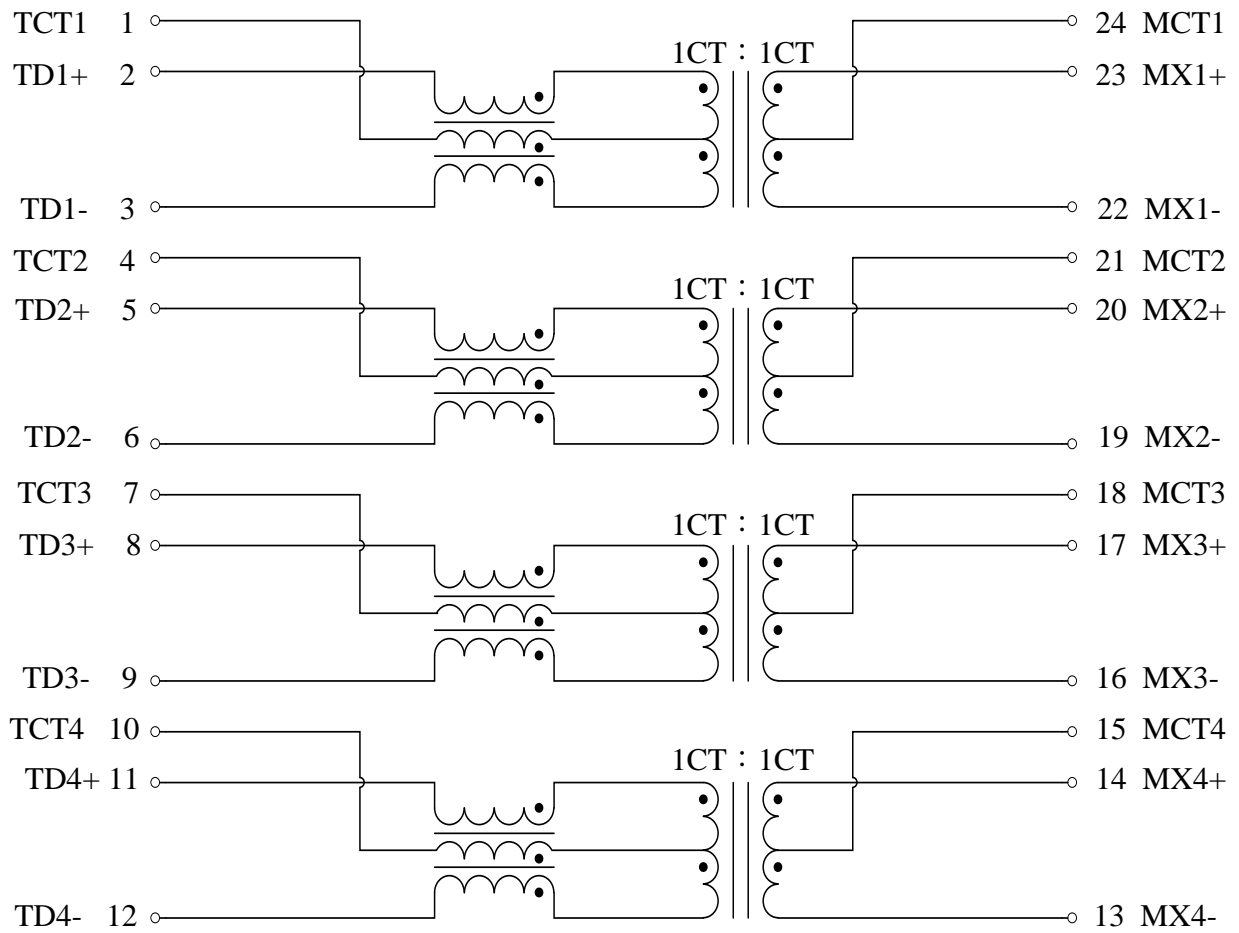

3.2 Electrical Specifications @25°C

Type : Balance low pass 100Ω impedance

3.2.1 Insertion Loss

1MHZ -0.55 dB Max

5MHZ -0.55 dB Max

200MHZ -0.77 dB Max

400MHZ -1.41 dB Max

3.2.2 Return Loss

1MHz -20 dB Min load 100Ω

100MHz -20 dB Min load 100Ω

200MHz -18 dB Min load 100Ω

300MHz -15 dB Min load 100Ω

400MHz -10 dB Min load 100Ω

500MHz - 8 dB Min load 100Ω

3.2.3 Reflected CM to Diff Conversion (REF)

50MHZ -30 dB Min

100MHZ -27 dB Min

200MHZ -24 dB Min

300MHZ -22 dB Min

400MHZ -21 dB Min

500MHZ -20 dB Min

3.2.4 Reflected Diff to CM Conversion (REF)

1MHZ -48 dB Min

100MHZ -33 dB Min

400MHZ -24 dB Min

500MHZ -24 dB Min

3.2.5 CM to DM Conversion (REF)

50MHZ -40 dB Min

100MHZ -35 dB Min

200MHZ -30 dB Min

300MHZ -22 dB Min

400MHZ -17 dB Min

500MHZ -17 dB Min

3.2.6 CM to CM Attenuation

1MHZ -22 dB Min

500MHZ -20 dB Min

800MHZ -20 dB Min

1000MHZ -17 dB Min

3.2.7 Cross Talk

1MHZ -34 dB Min

350MHZ -23 dB Min

500MHZ -23 dB Min

3.3 Inductance

@ 100KHz, 0.1V, 8mA DC BIAS 160uHMin

3.4 HiPot Test

@ 1500 Vrms

3.5 Turns Ratio

@ 1:1±5%

4. IR REFLOW TEMPERATURE PROFILE

Step#	Profile Feature	Condition/Duration
Step1	Ramp-up rate	3°C/sec max
Step2	Preheat : 150~200°C	Ta-Tb : 60-180sec
Step3	Ramp-up rate (TL to Tp)	3°C/sec max
	Temperature maintained above 217°C (TL)	tl : 60-150sec
Step4	Measured Peak temperature of pin (Tp) Set Reflow Peak Temp.	260°C
	The Time of Actual Peak temperature	20-40sec
Step5	Ramp-down rate	6°C/sec max
Note1	All temperatures refer to topside of the package, measured on the package body surface	
Note2	Time 25°C to peak temperature : 8 minutes max.	
Note3	It is not allowed to make a forced cooling in temperature falling range.	
Note4	The applicable condition refer to IPC/JEDEC J-STD-020D standard	

Table 1 Pb-Free Process-Classification Temperatures (Tp)

Package Thickness	Volume mm3 <350	Volume mm3 350-2000	Volume mm3 >2000
<1.6mm	260°C	260°C	260°C
1.6mm-2.5mm	260°C	260°C	260°C
>2.5mm	260°C	260°C	260°C

