



UDE 湧德電子

Business Review and Outlook

陳伯榕

Gary Chen

Apr 2022

全球 RJ-45 ICM出貨量第一



成立於2005年

股票代號: 3689 TT

集團員工: 3,000 人

整合型訊號連接器 RJ-45 專業製造廠

2021年度合併營收淨額 約NT\$62億元

- 集團營運中心: 台灣桃園
- 大陸四川廠: 主要生產基地
- 大陸東莞廠: 生產高附加價值產品、新產品及自動化設備設計及研發

競爭對手



高進入門檻：與一般連接器同業比較

RJ45 ICM廠商需兼具傳統連接器生產能力與高速資訊傳輸技術

一般連接器廠商

產品精度

機構設計

精密射出

高速衝壓

精密模具設計

湧德- RJ45 ICM

傳輸速度

電子/機構

雜訊抑制

線路保護

電子電路設計

湧德優異訊號處理及產品客製化能力

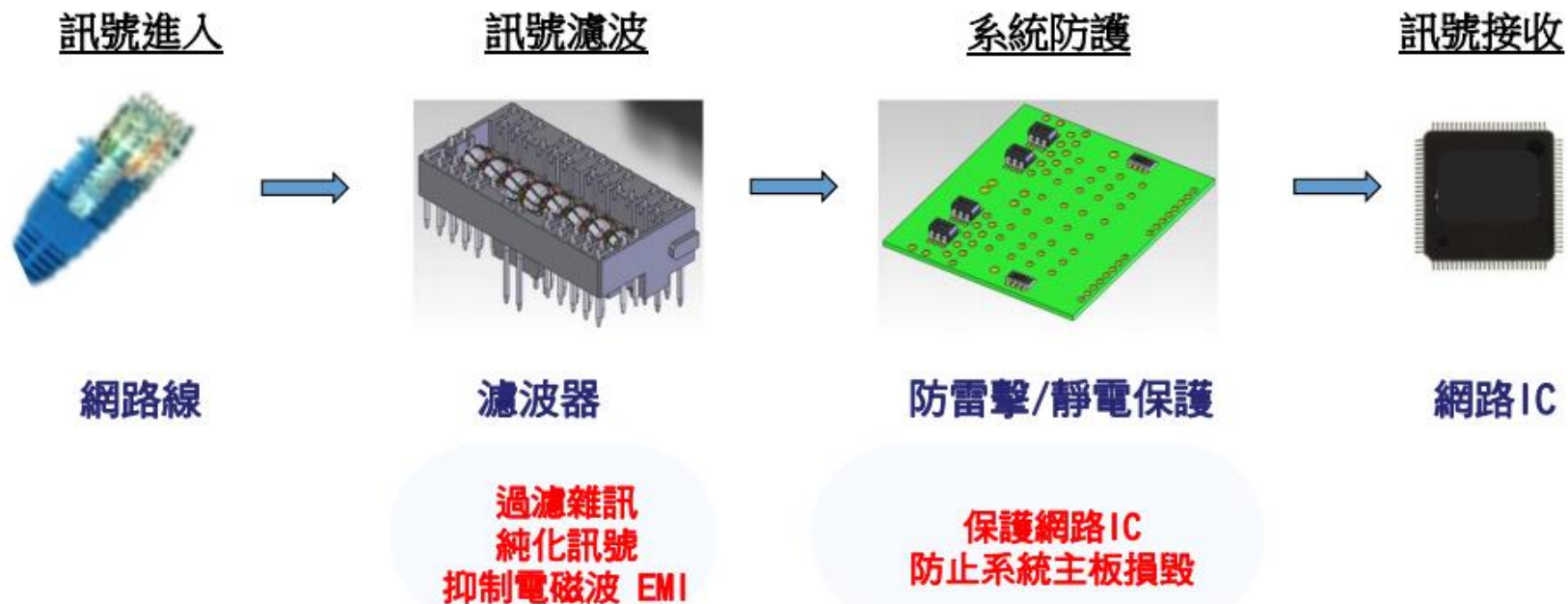

因應客戶系統進行高頻電路阻抗客製化匹配設計

目標：維持最佳訊號雜訊比,確保訊號完整且快速傳遞至客戶主板上的網路IC

湧德 – 全方位的RJ45產品應用

	網通	電腦	消費性產品
	√	√	√
	√	√	
	√		
	√		
	√		
	√		
	√		√

每月營業收入

NT\$ million

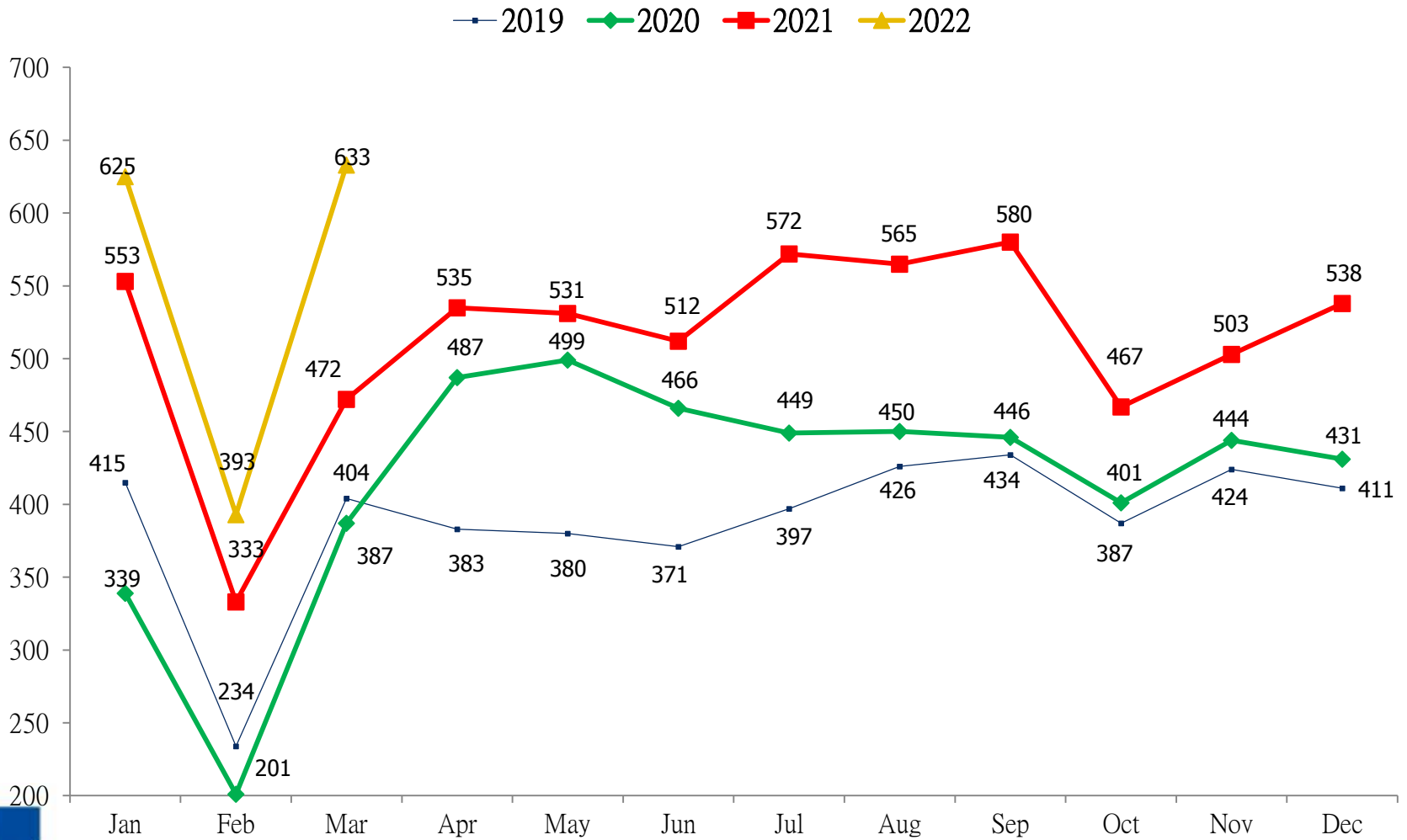

季度營收趨勢

YoY Growth

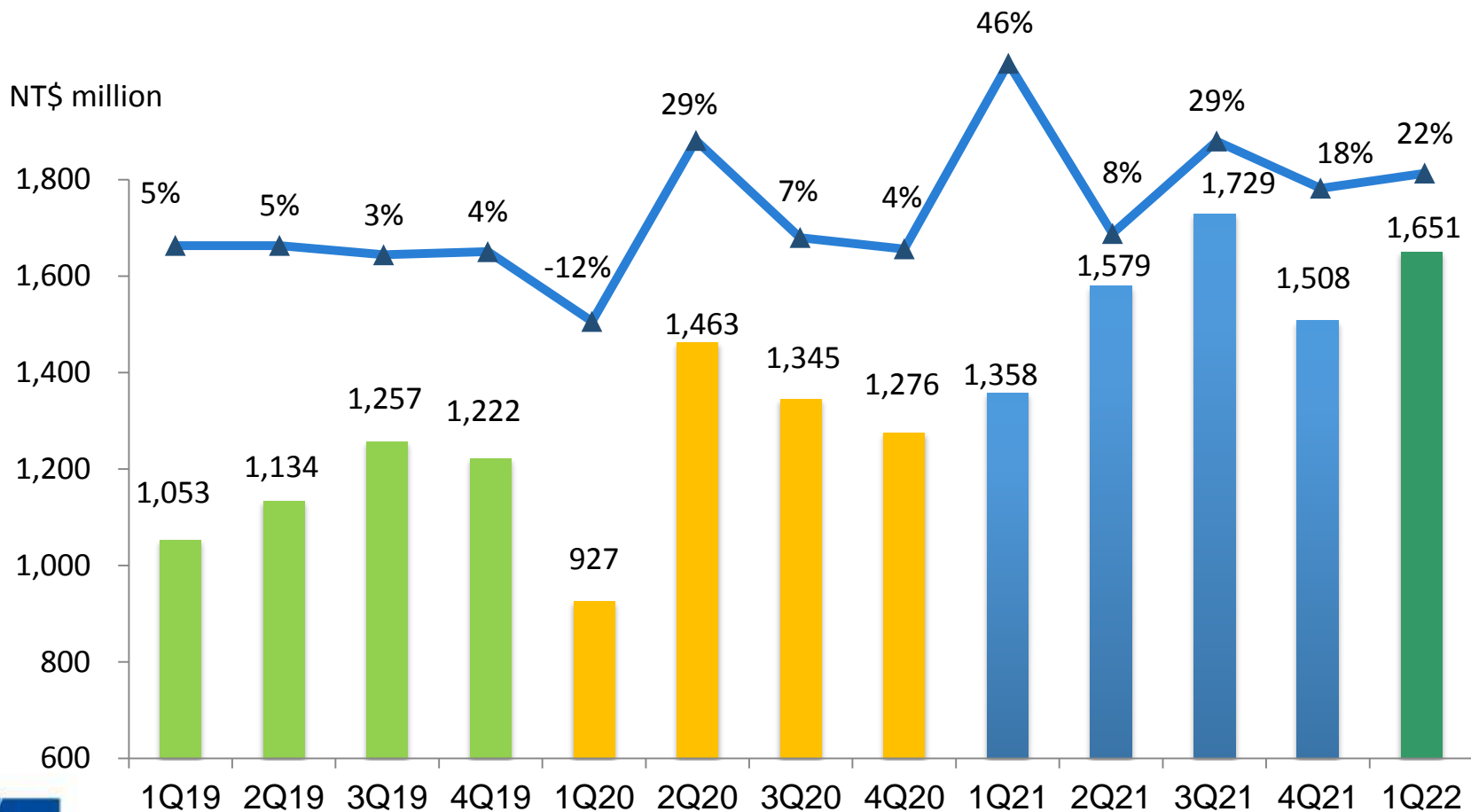

應用領域營收分布-RJ45

NT\$ million

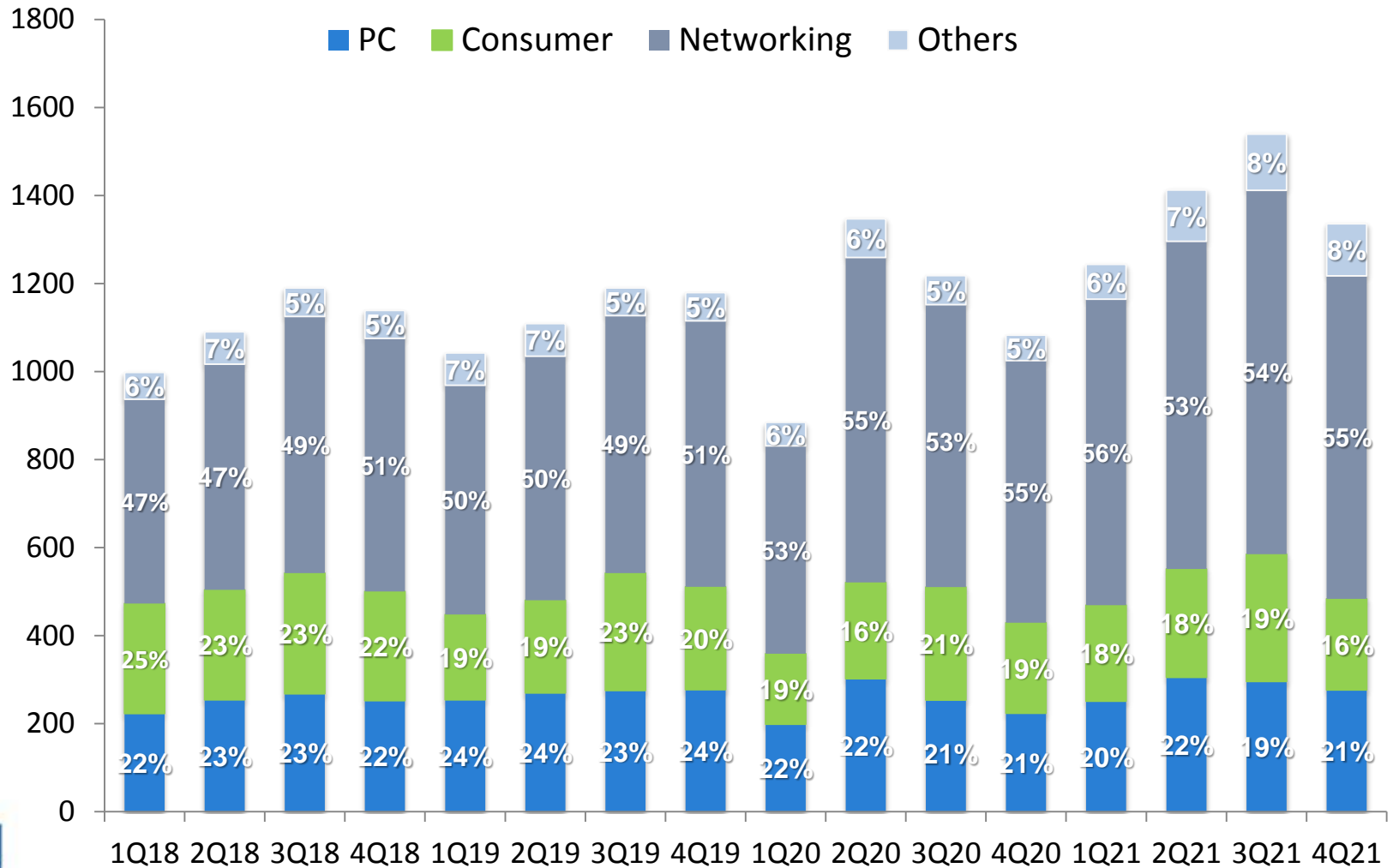

營業毛利與營業淨利

Gross Margin %

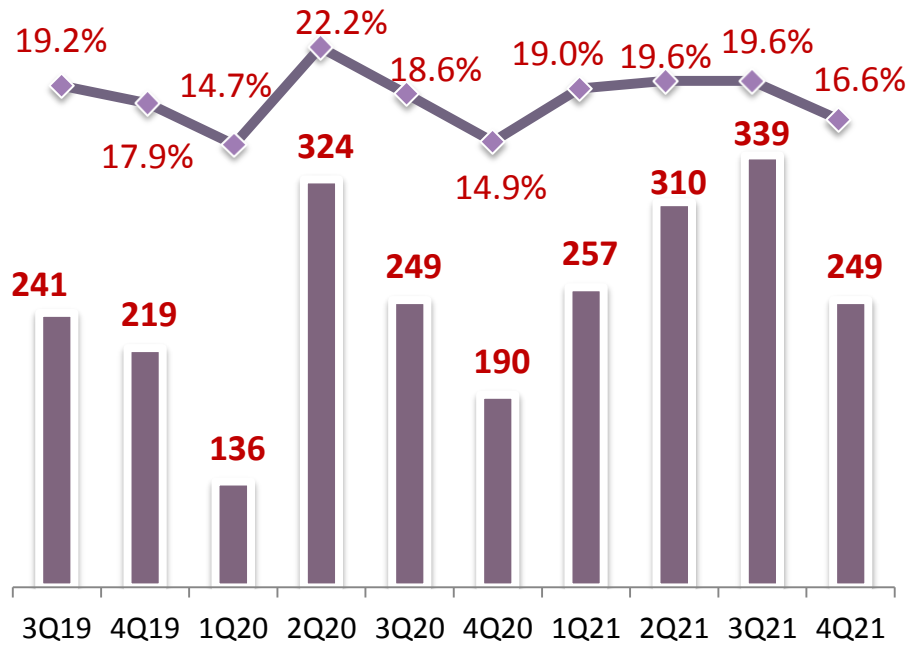

Gross Profit NT\$ million

Operating Margin %

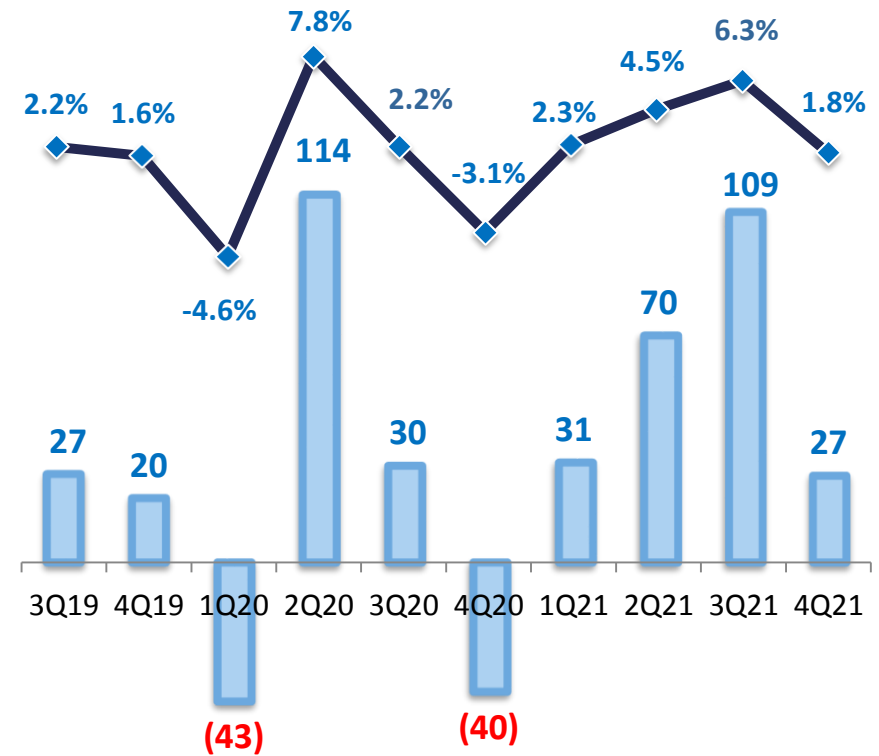

Operating Profit NT\$ million

2021年 損益表

NT\$ million	2021	2020	YoY%
Revenue	6,164.7	5,008.4	23.0
Gross Profit	1,155.7	899.6	28.0
Operating Expenses	(912.3)	(836.9)	(9.0)
Operating Profit(loss)	243.3	62.7	288.0
Foreign exchange gain/(loss)	6.9	18.3	(62.0)
Non Operating Income/(Loss)	45.0	35.1	28.0
Income Before Tax	295.2	116.1	154.0
Taxes	(42.8)	(23.4)	(83.0)
Non-controlling Interests	(12.2)	4.3	(384.0)
Net Income to Parent	240.2	97.0	148.0
EPS (NT\$)	3.28	1.39	136.0

Key Financial Ratios (%)

Gross Margin	18.7	18.0
Operating Expense Ratio	(14.8)	(16.7)
Operating Margin(loss)	3.9	1.3
Net Margin to Parent	3.9	1.9

Other Information

Effective Tax Rate (%)	(14.5)	(20.2)
------------------------	---------------	---------------

2021年 資產負債表

NT\$ million	2021	%	2020	%	3Q21	%
TOTAL ASSETS	5,760.1	100	5,659.0	100	5,866.0	100
Cash	356.3	6	750.9	13	342.2	13
NR & AR	1,769.6	31	1,358.3	24	1,879.7	20
Inventory	1,481.2	26	1,164.8	21	1,406.0	19
Property, plant and equipment	1,558.0	27	1,651.5	29	1,616.6	29
TOTAL LIABILITIES	2,798.3	49	3,015.6	53	2,997.3	50
Bank Loans	1,026.7	18	1,047.0	19	1,076.8	26
NP & AP	636.4	11	539.8	10	677.7	7
Other Payables	682.7	12	671.2	12	719.1	10
Bonds Payable	63.4	1	575.6	10	141.5	5
TOTAL EQUITY TO PARENT	2,918.5	51	2,594.2	46	2,814.2	43
Capital	766.7	13	696.8	12	742.4	12

Key Financial Ratios (%)

Current Ratio	135	136	119
Debt Ratio	49	53	51
Book Value (NT\$/share)	38	37	38

銷售、管理、研發費用

NT\$ million

■ Selling ■ G&A ■ R&D

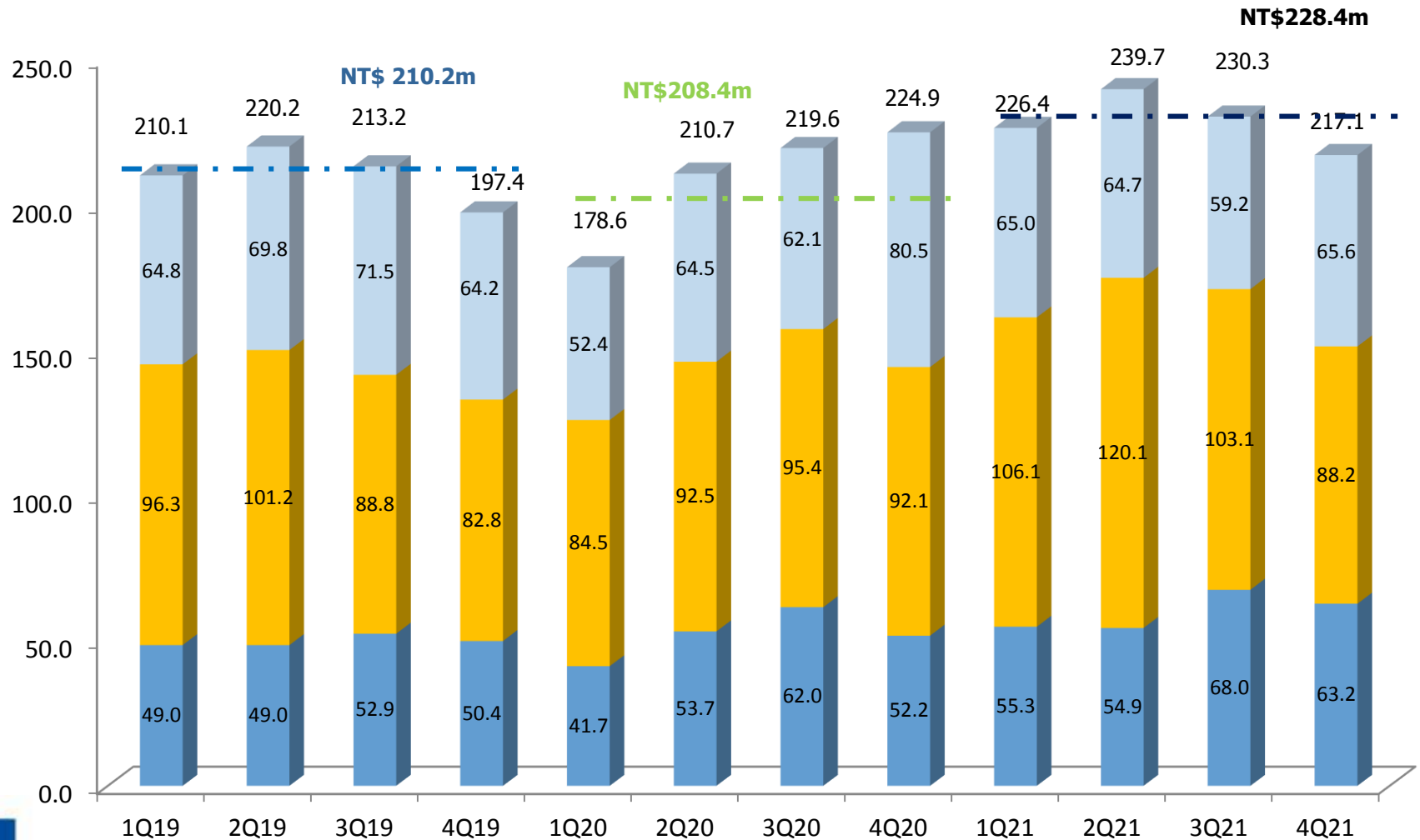

營業費用結構

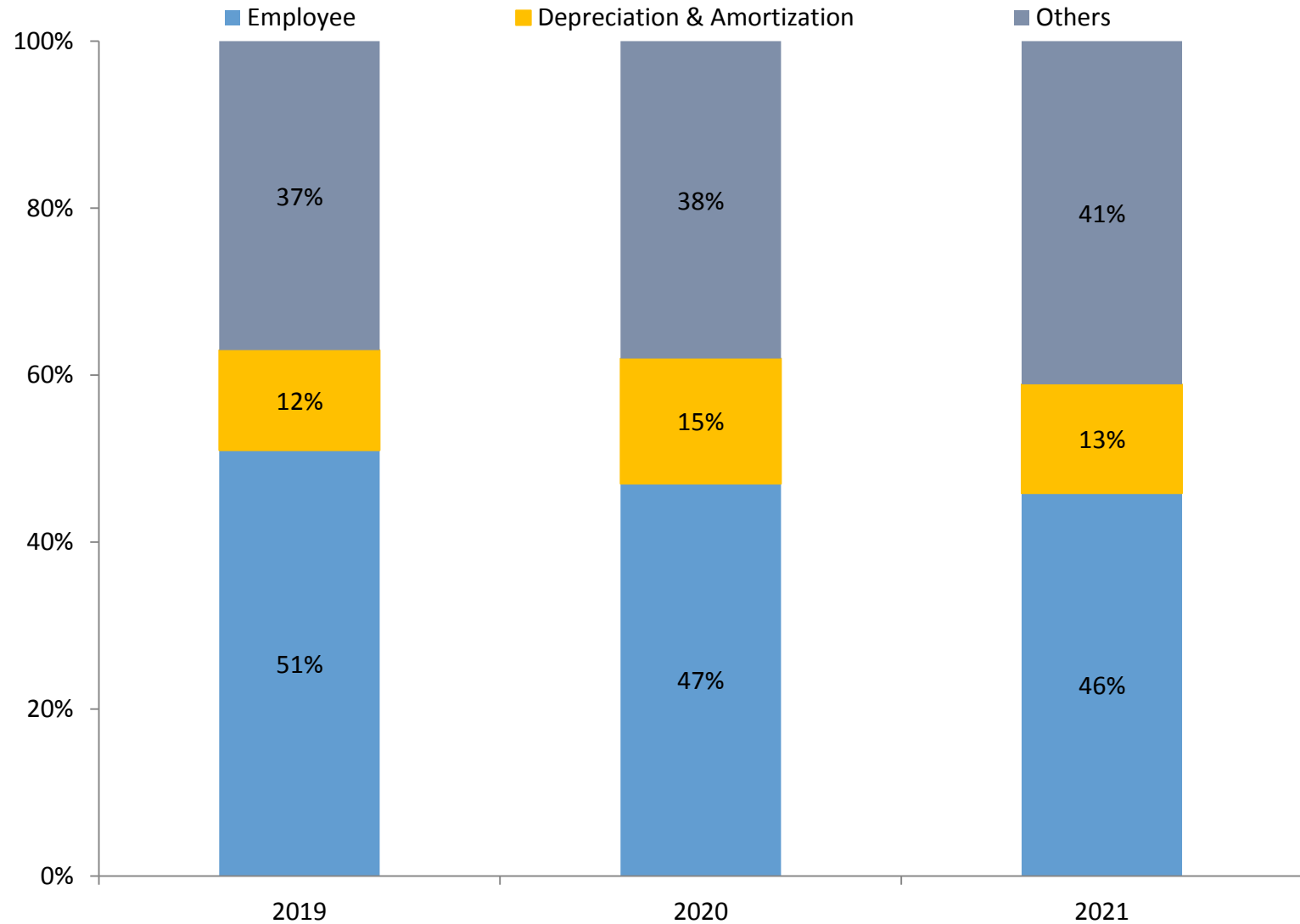

用人成本及費用

NT\$ million

■ Operating cost ■ Operating expenses

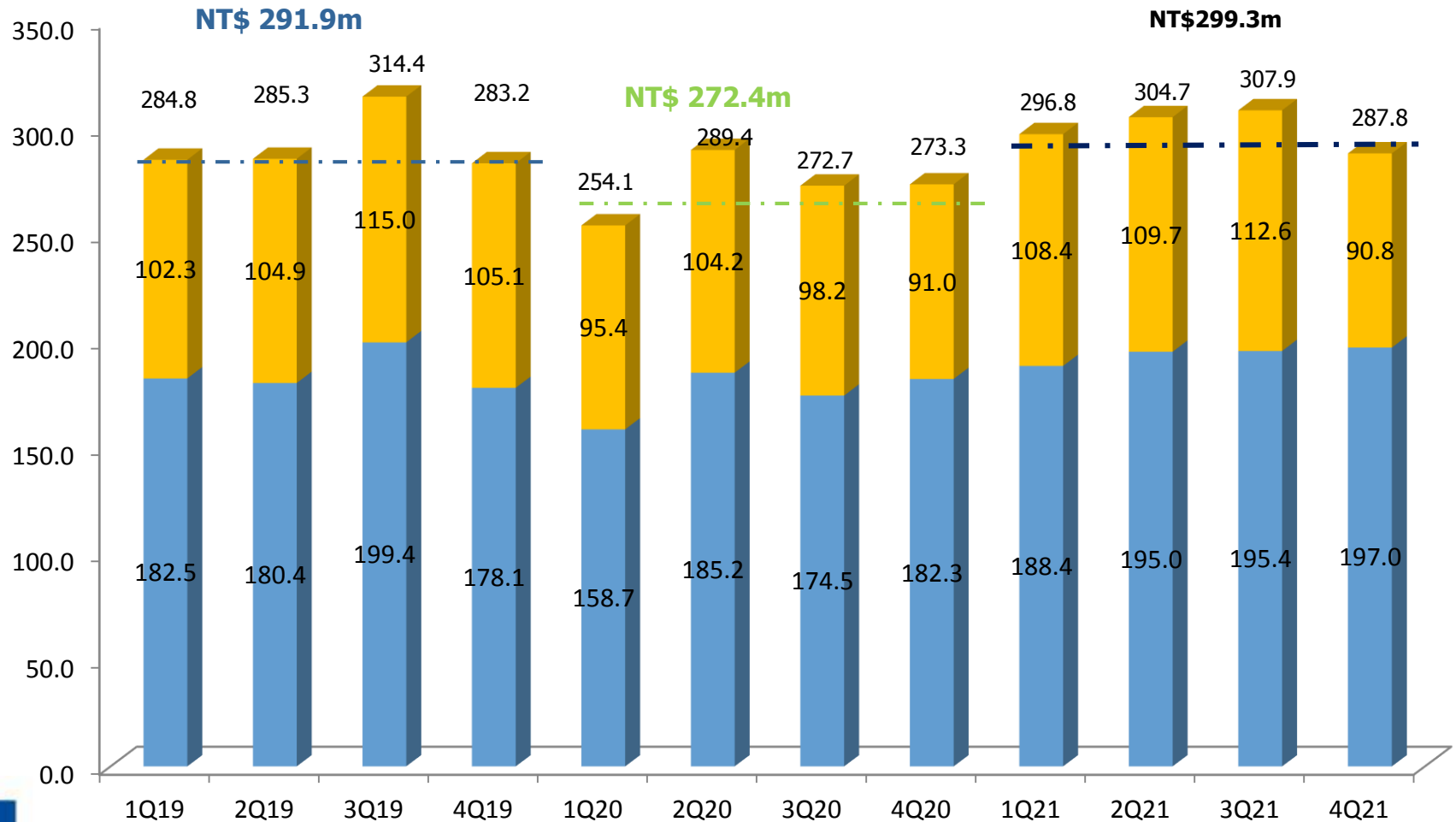

人力資源分布情形

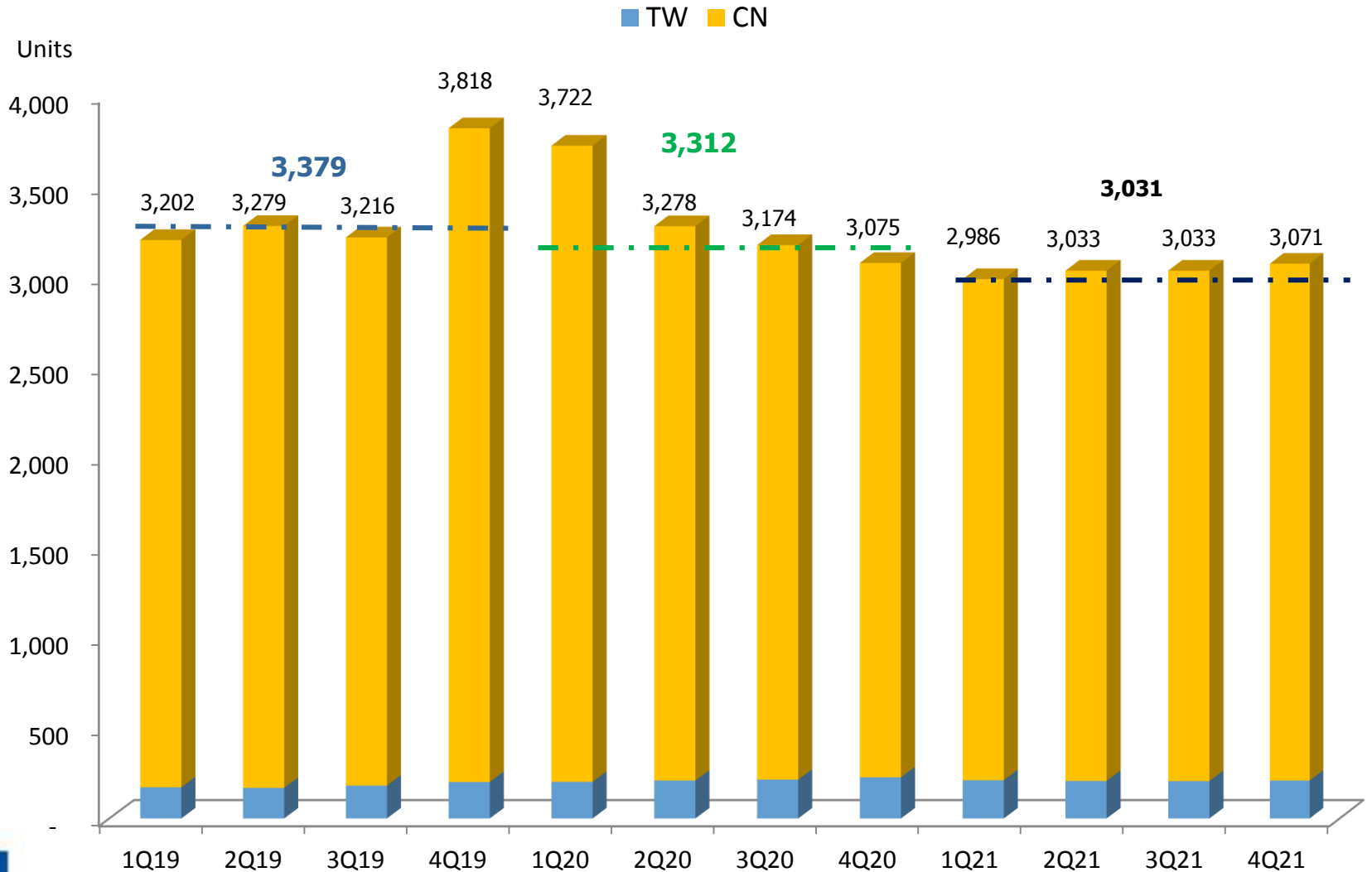

存貨狀況

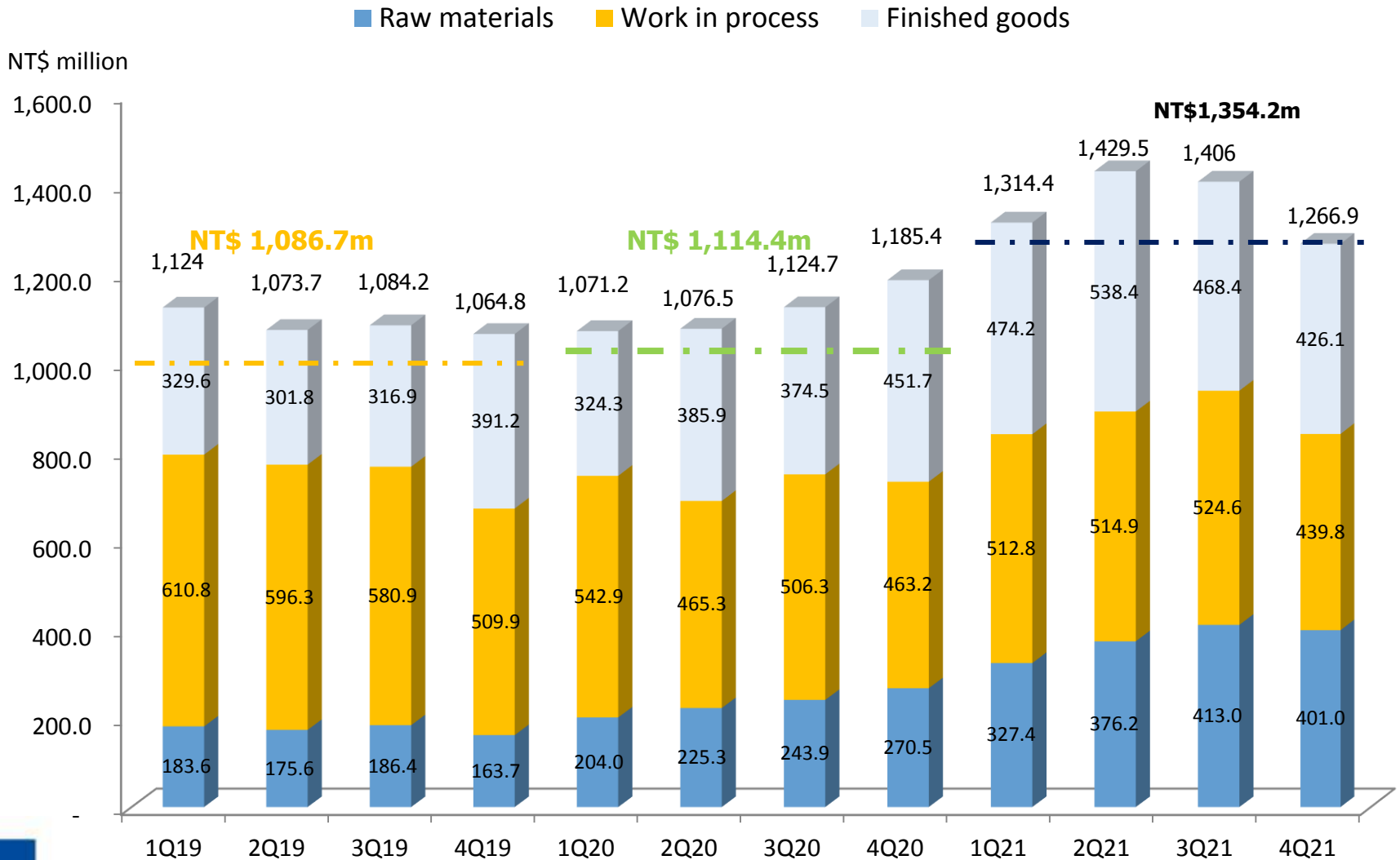

折舊與攤銷費用狀況

NT\$ million

■ Operating costs ■ Operating expenses

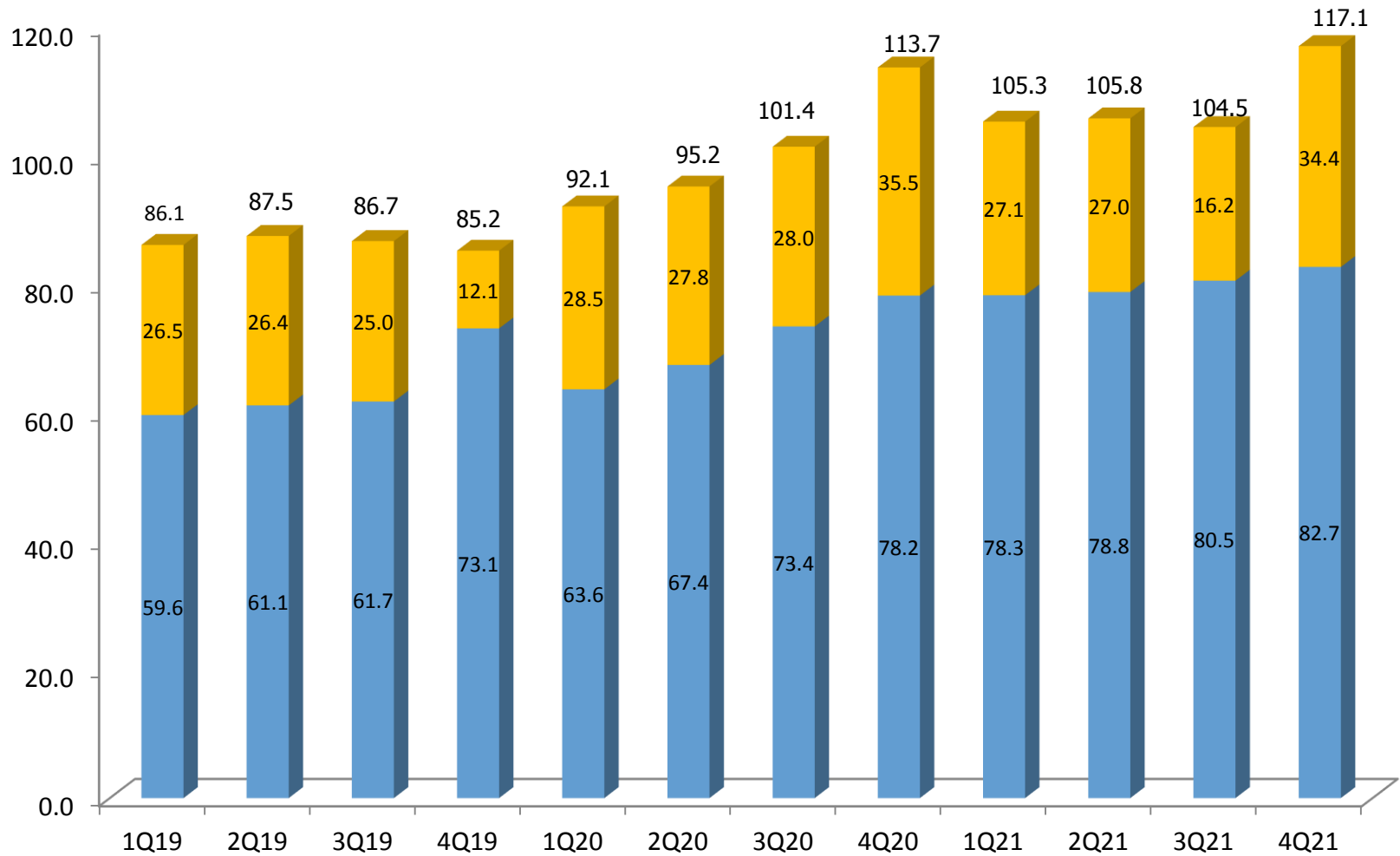

市場概況

Ethernet Provider. Solution!



Ethernet 應用

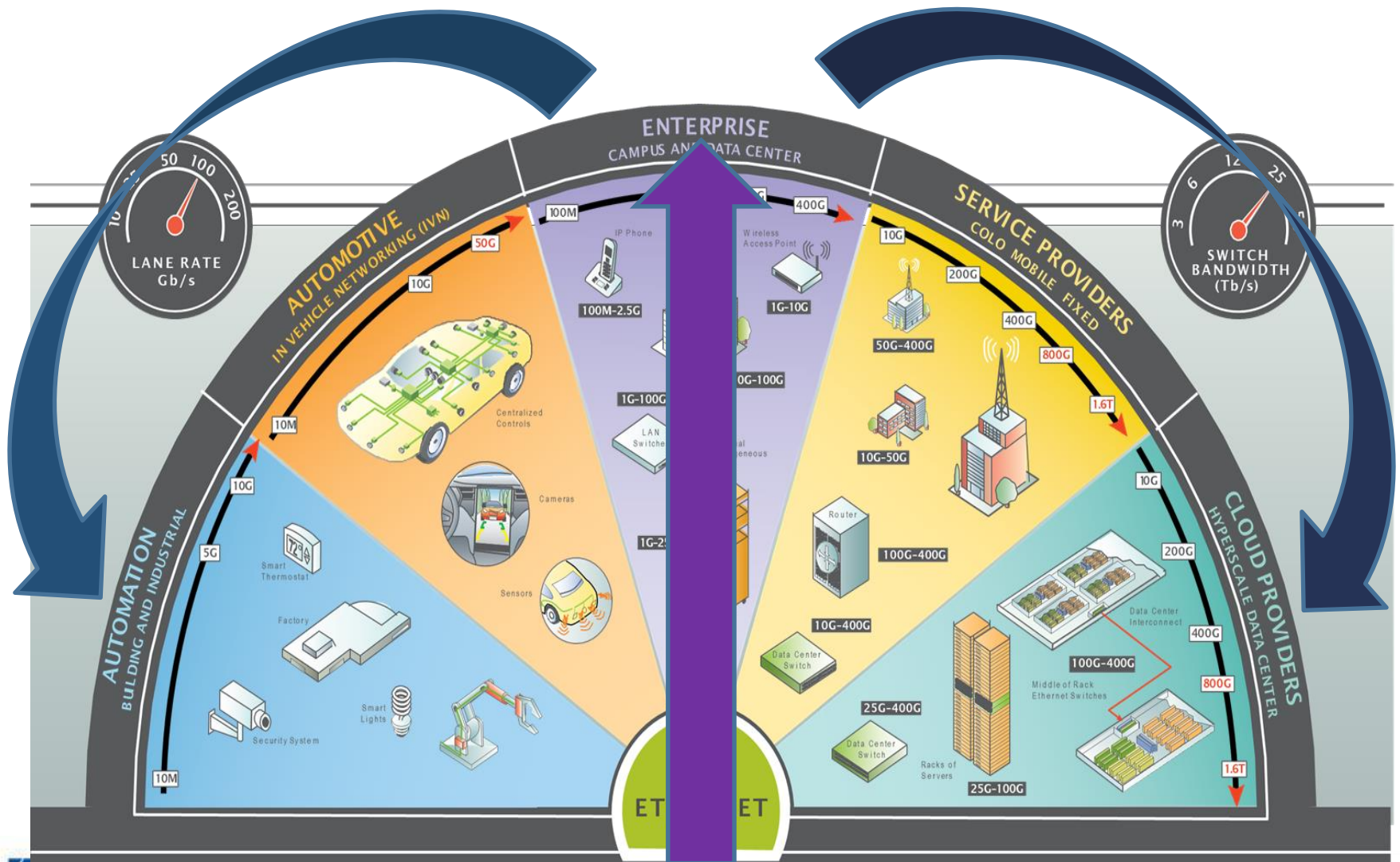

Ethernet Speeds

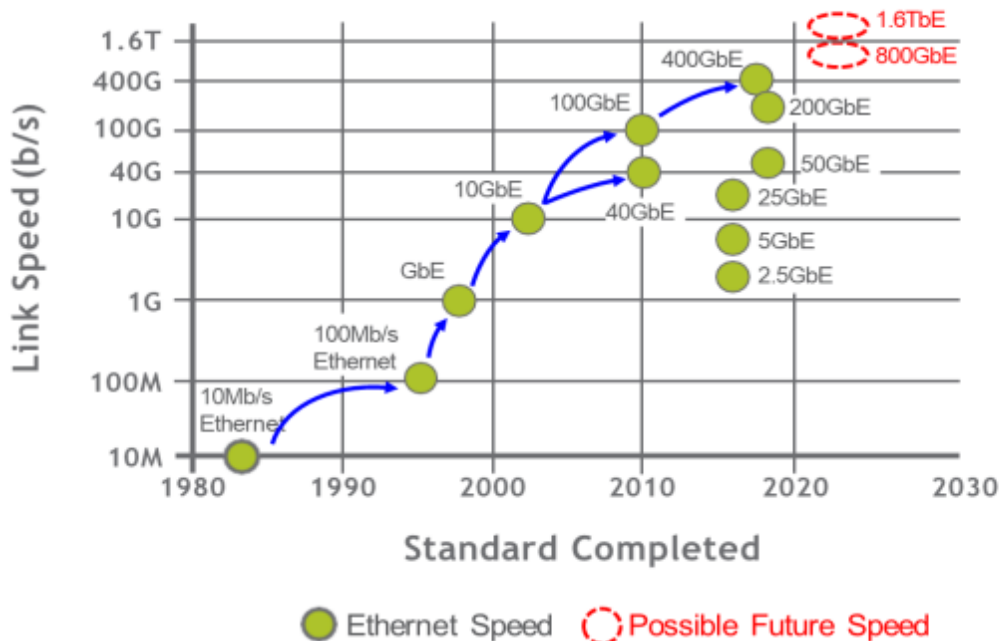

Form Factors

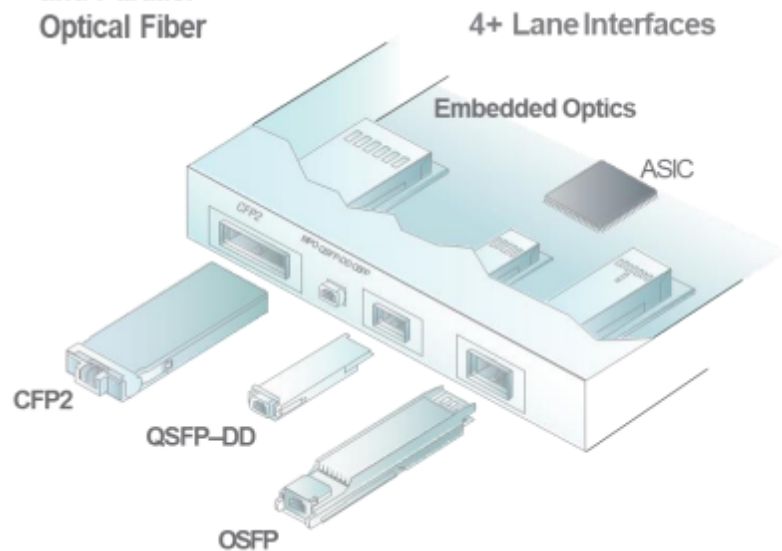
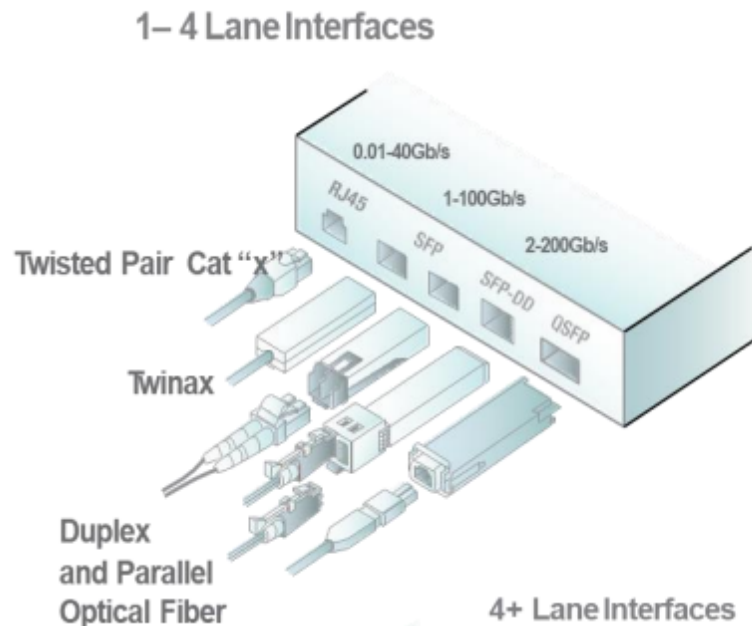

PoE

PoE Types and Classes	2-Pair PoE+ – Type 2					4-Pair PoE in Standardization			
	2-Pair PoE – Type 1					5	6	7	8
Class	0	1	2	3	4				
PSE Power (W)	15.4	4	7	15.4	30	45	60	75	90
PD Power (W)	13	3.84	6.49	13	25.5	40	51	62	71.3

4-Pair PoE-Type 3 (Classes 0-4)
4-Pair PoE Type 4 (Classes 5-8)

ICM RJ (PoE)

10M/100M → 1G → 2.5G/5G → 10G

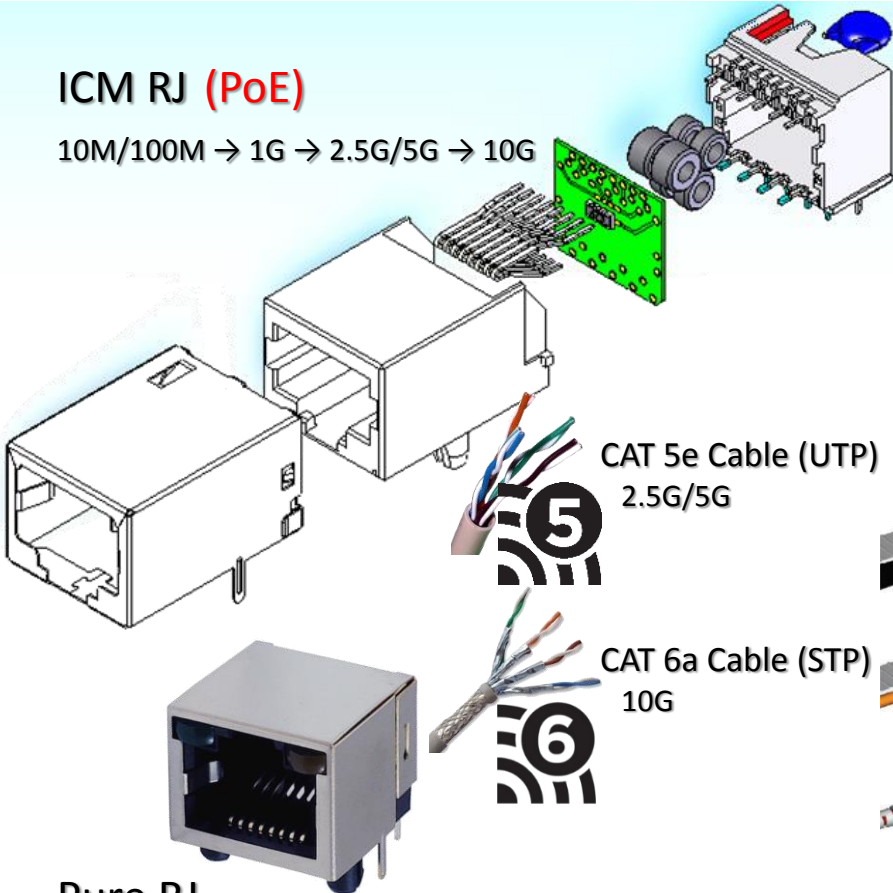

CAT 5e Cable (UTP)
2.5G/5G



CAT 6a Cable (STP)
10G



Pure RJ

10M/100M → 1G → 2.5G/5G → 10G

SFF Series (SFP, SFP+, SFP28, QSFP+, SFP DD, QSFP28, QSFP DD, OSFP)

1G → 10G → 25G → 40G → 50G → 100G → 200G → 400G → 800G

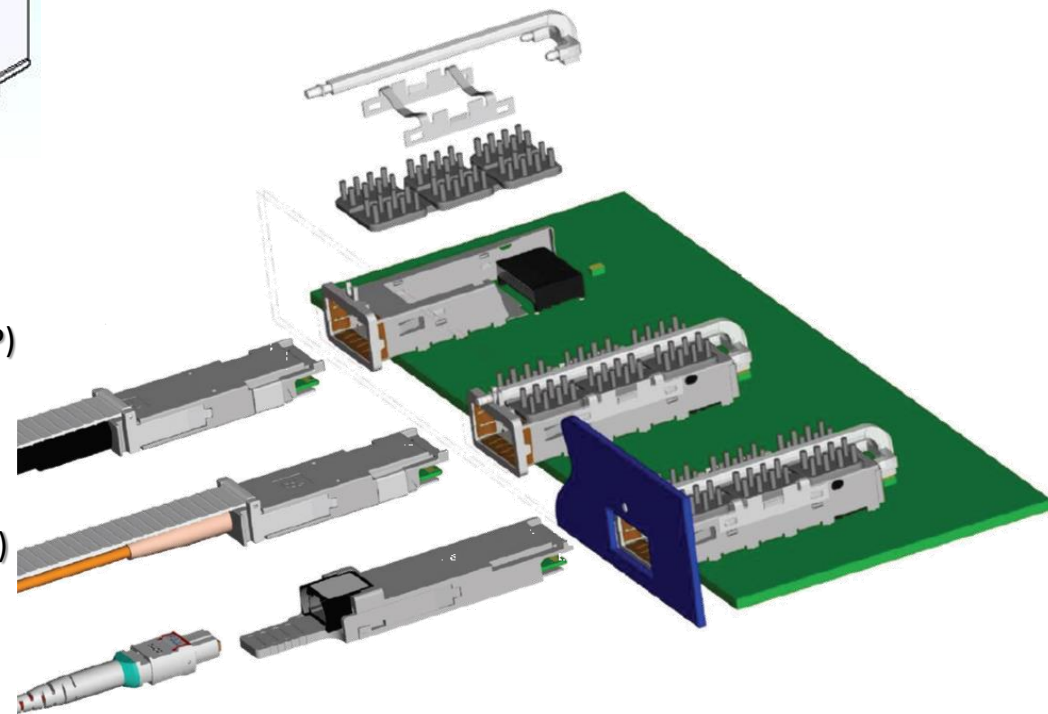

SFF產品系列

Series	Speed	Connector / Cage	Cable
SFP	1G	√	√
SFP+	10G	√	√
SFP 28	25G	√	√
QSFP+	40G	√	√
QSFP 28	100G	√	√
QSFP 112	400G	√	
QSFP-DD	400G	√	
QSFP-DD 112	800G	√	
QSFP-DD Flyover	800G	√	

- ICM RJ
- Pure RJ
- PoE

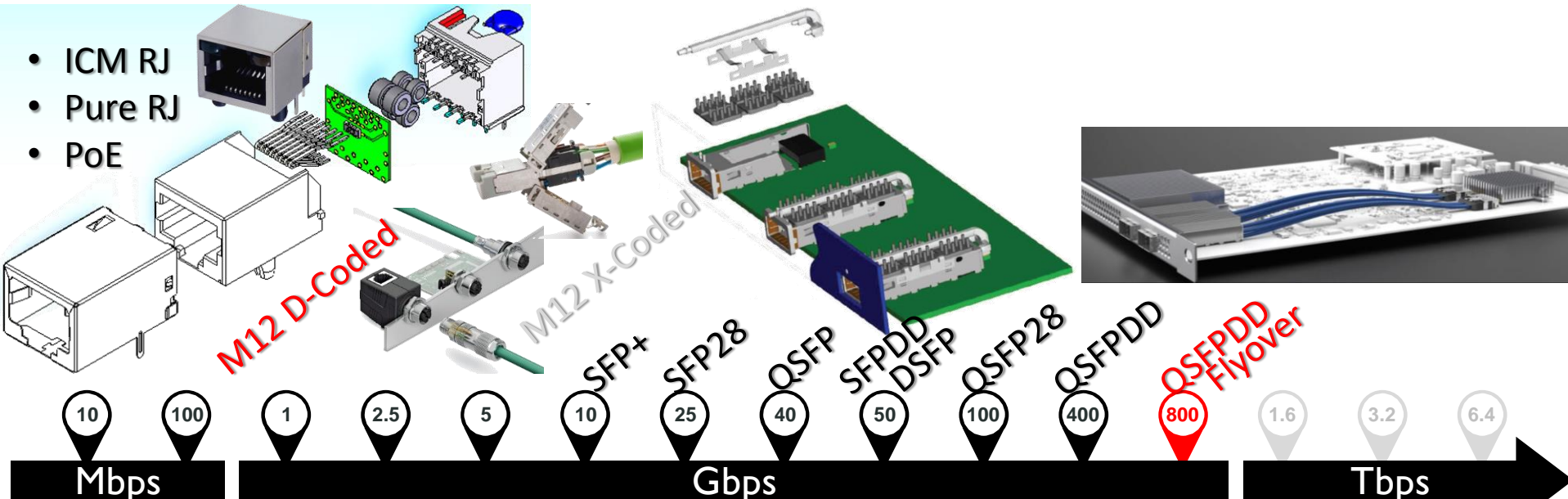

- Desktop
- Notebook
- Printer
- Blue-Ray DVD
- Set top Box
- TV

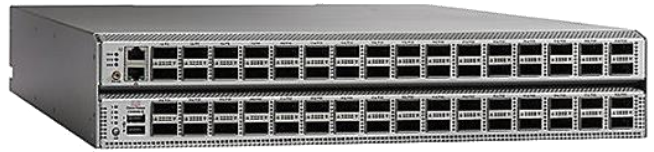

產品佈局

1. 板端 : I/O Connector
2. 外線 : External I/O Cable
3. 板內 : Internal Connector
4. 內線 : Internal Cable

長期產品計畫

Back	Connector		Cable Assembly	
	External IO	On Board	External	Internal
SFF Series	●		●	
SAS Series	●	●	●	●
OCuLink	●	●	●	●
Fly-Over	●	●		●
B-2-B		●		
Backplane Connector		●		●

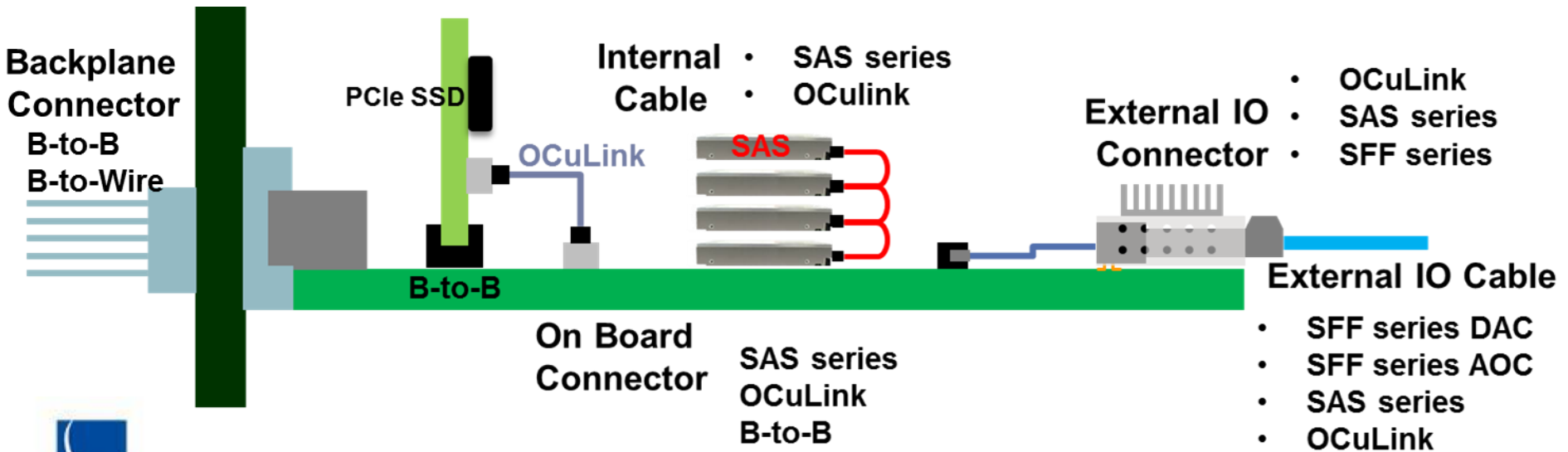

Thank
You

