

APPROVAL SHEET

To :

Customer P/N :

UDE P/N : RTA-ZZ-0073

Description : RJ45 1X1 Tab Up

Through Hole

10/100/1000 Base-T

Contact Area : 30 μ " Min. Gold

LED : L-Green; R-Green/Orange

Packing With Hard Tray



Spec No.
RTA19025-00

Update Date
2019/5/16

Revision
A

Approved	Checked	Prepared



湧德電子 股份有限公司
UDE Corp.

桃園市(33852) 蘆竹區內溪路 68 巷13號

No.13, Ln. 68, Neixi Rd., Luzhu Dist., Taoyuan City (33852), Taiwan

TEL: 886-3-3242000 FAX: 886-3-3246611

<http://www.ude-corp.com/>

1. MECHANICAL DIMENSION

Product Dimension

Unit:mm	General Tolerance :	X.X : ± 0.38
		X.XX : ± 0.20

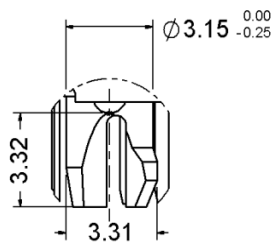
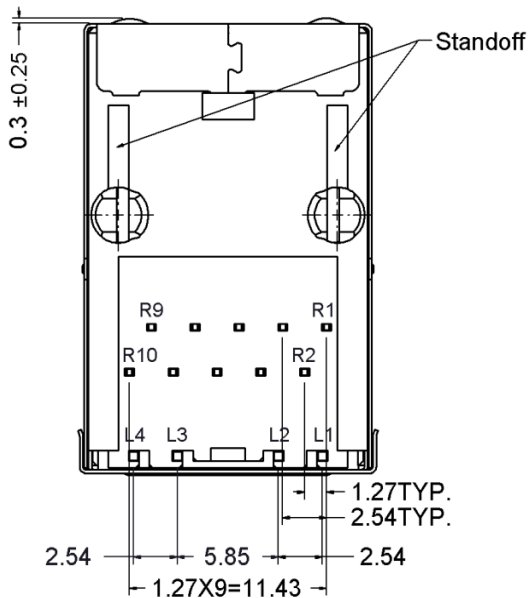
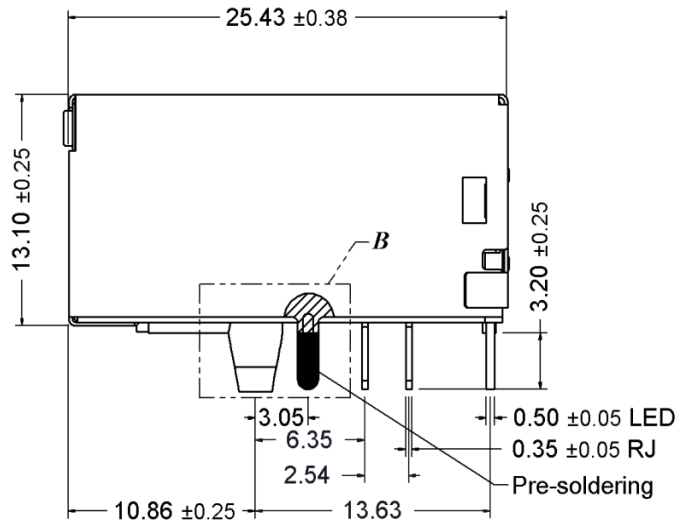
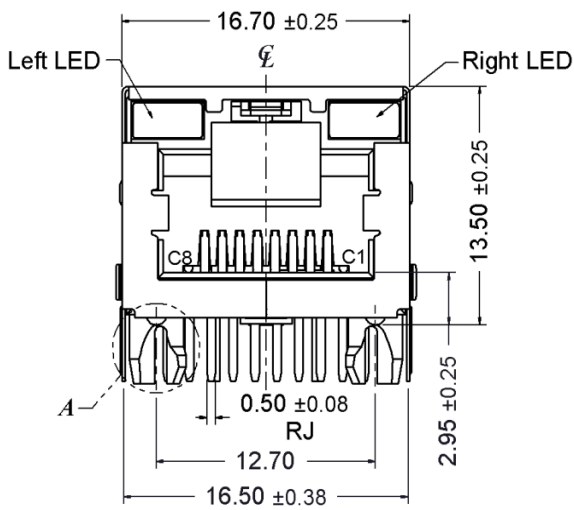
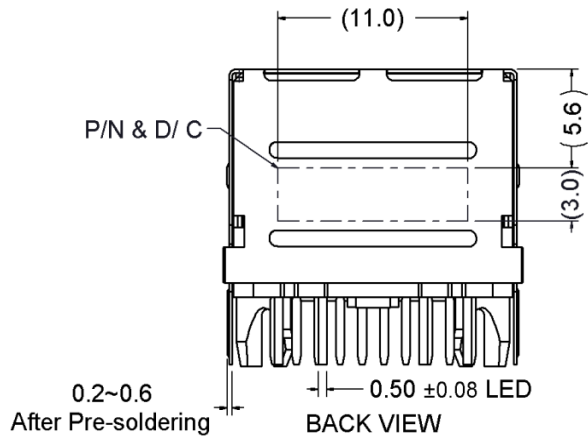
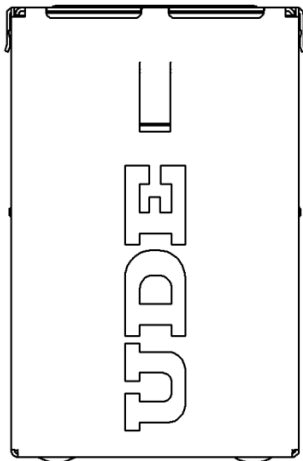

DETAIL A

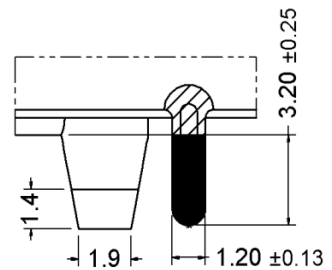

DETAIL B

Recommended PCB Layout. Component side of board

All dimension units are "mm".

All dimension tolerances are ±0.05mm unless otherwise specified.

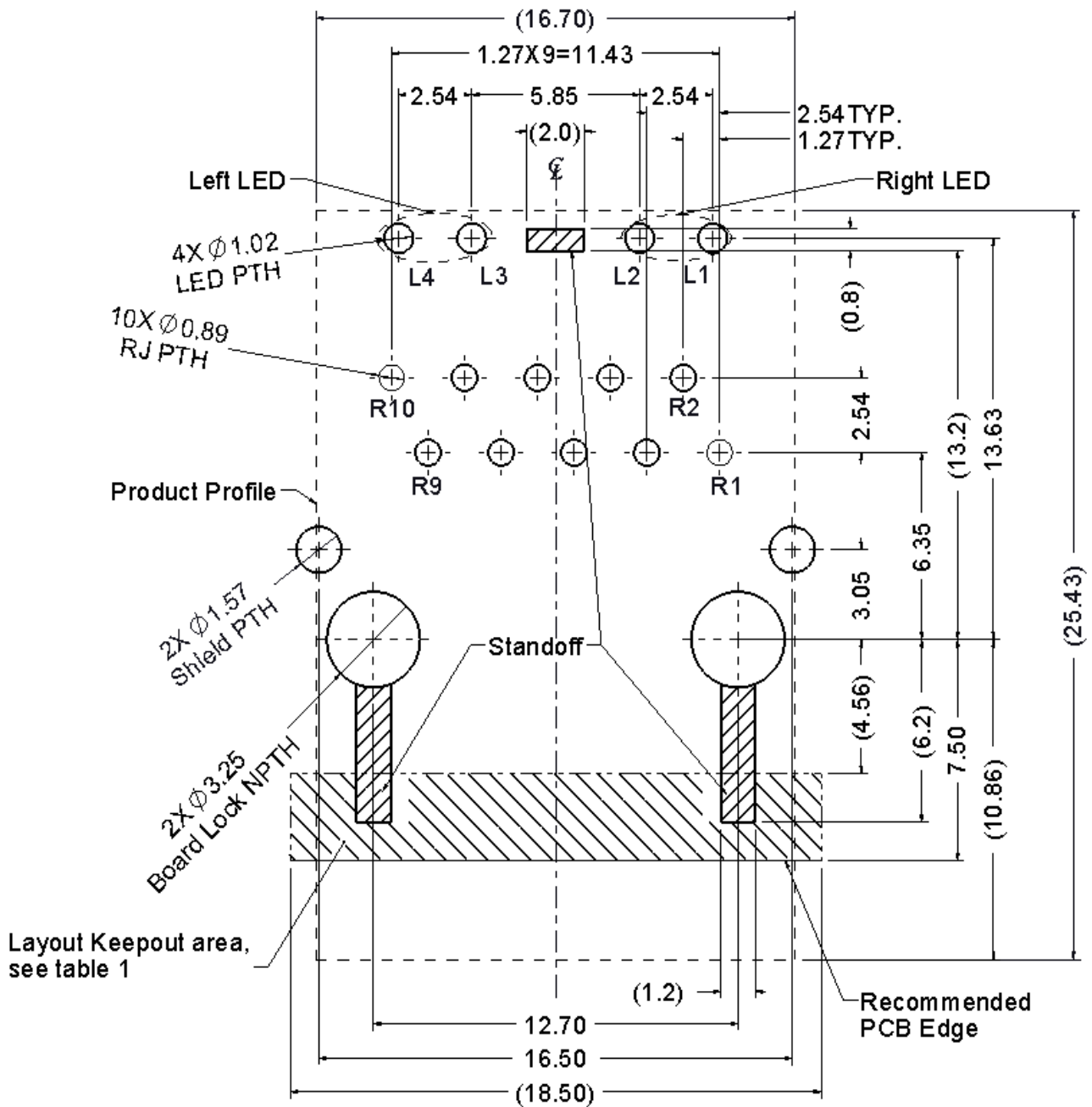
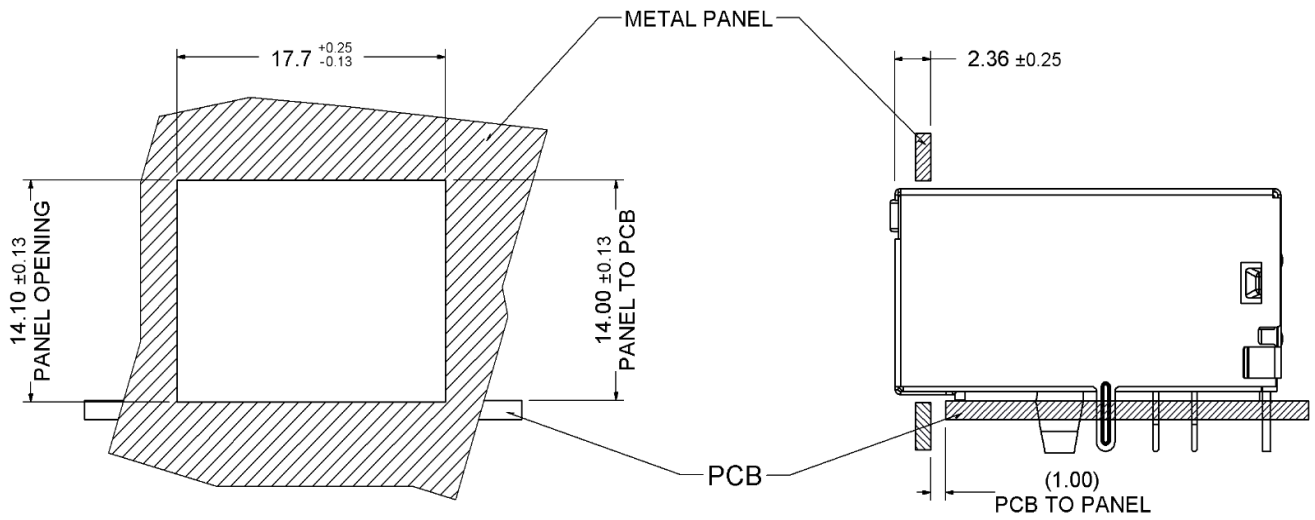

Table1

Layout Layer	Trace	component	Grounding	Test Point	Via Hole	PTH	NPTH
Component side	X	X	O	X	X	X	O
Inner layer	O	NA	O	NA	O	X	O
Bottom side	O	O	O	O	O	X	O

X--Forbid; O--OK; NA--Not Applicable.

Recommended Panel cutout



2. Packing Information

36 pcs finished goods per tray

8 trays(252 pcs finished goods) per inner box

4 Inner boxes(1008 pcs finished goods) per master carton

3. Standard RJ45 Plug Specification

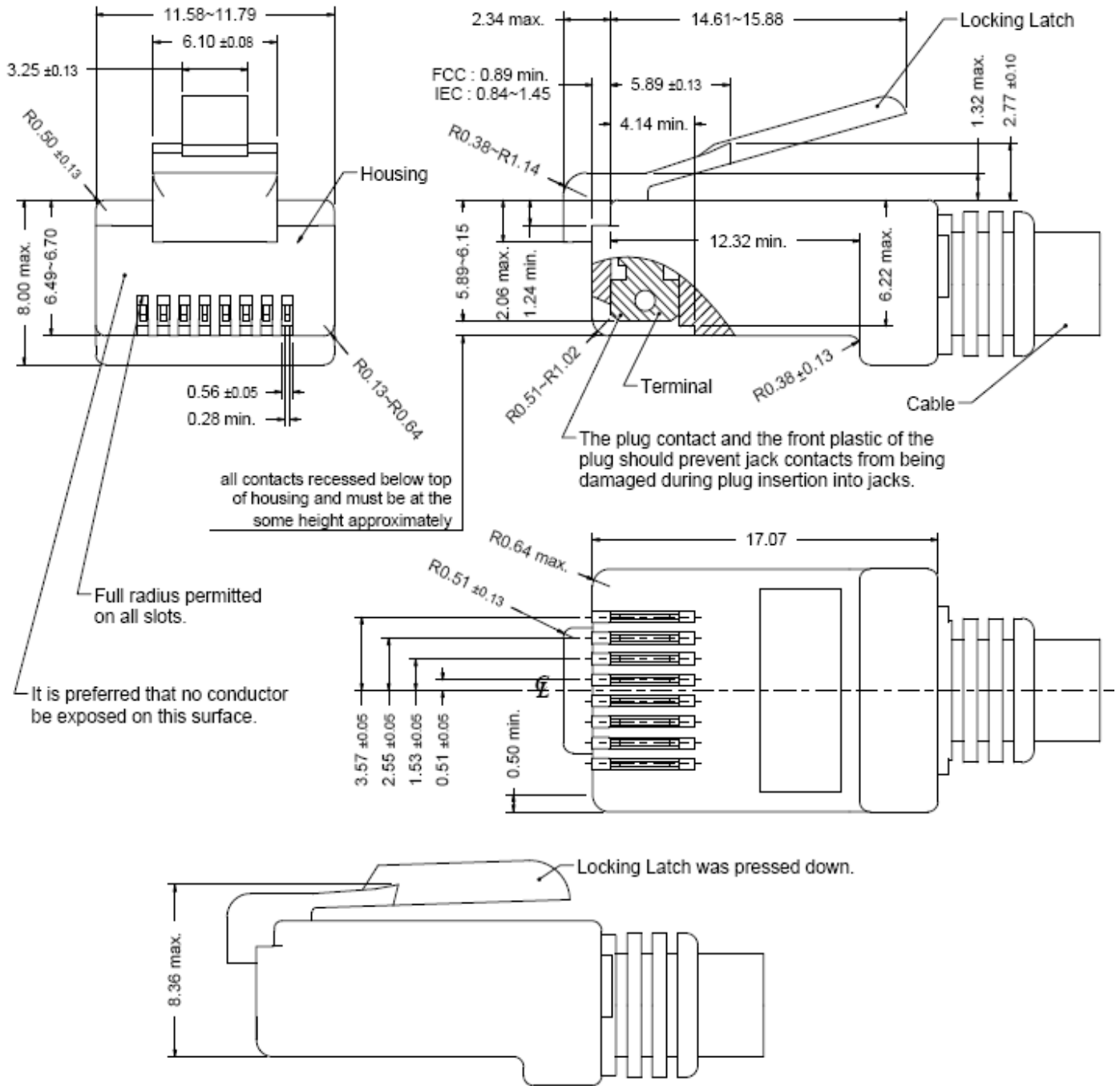

- All dimensions follow :
FCC subpart F, 68,500, Figure (C)(2)(i) & (C)(2)(ii) & (C)(3)(i)
IEC 60603-7
- All plugs must be meeting the requirements of plug Go & No-Go gauge.
Gauge follow : FCC subpart F, 68,500, Figure (C)(4)(i) & (C)(5)(i)
- There must be no damage to Housing and Locking Latch.
- There must be no nicks and cuts in cable.
- Durability : 750 cycles generally

4. REQUIREMENTS

Design and Construction

Product shall be of design, construction and physical dimensions specified on applicable.

Material

Terminal Parts (Underplating : 50 μ " min. Nickel overall)

RJ Terminal : Phosphor Bronze, Thickness=0.30mm

Finish : Contact Area : 30 μ " min. Gold

Input Terminal : Brass, Thickness=0.35mm

Finish : 100 μ " min. Matte Tin

Case Terminal : CP Wire, Diameter=0.40mm

Finish : 100 μ " min. Matte Tin

Plastic Parts <UL94V-0>

Housing : PA6T, Black

Case : PF2A5-151J, Black

Spacer :PBT, Black

Cover : PBT, Black

Shield Parts : Stainless steel, Thickness=0.20mm, Pre-soldering

5. Operating and Storage Temperature

Operating Temperature : 0°C to +70°C

Storage Temperature : -40°C to +85°C

6. RJ45 specifications

Insulation Resistance : 500MΩ min.

Insertion force with the latch depressed : 20N max.

Removal force with the latch depressed : 20N max.

Locking Force of Plug Latch : 50N min. @ 60+/-5 sec.

Durability : 2500 cycles

7. Performance and Test Description

Product is designed to meet electrical, mechanical and environmental performance requirements specified in below table.

All tests are performed at ambient environmental conditions per MIL-STD-1344A and EIA-364 unless otherwise specified.

8. Packaging and Packing

All parts shall be packaged and packed to protect against physical damage, corrosion and deterioration during shipment and storage.

9. ELECTRICAL CHARACTERISTICS @25°C

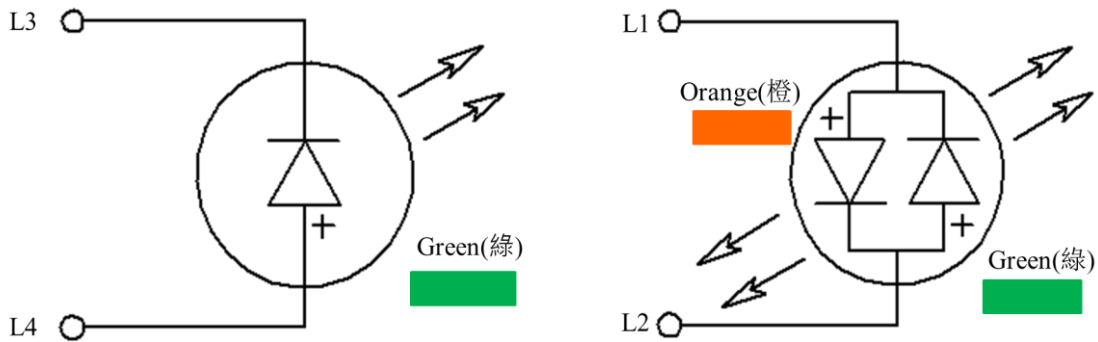
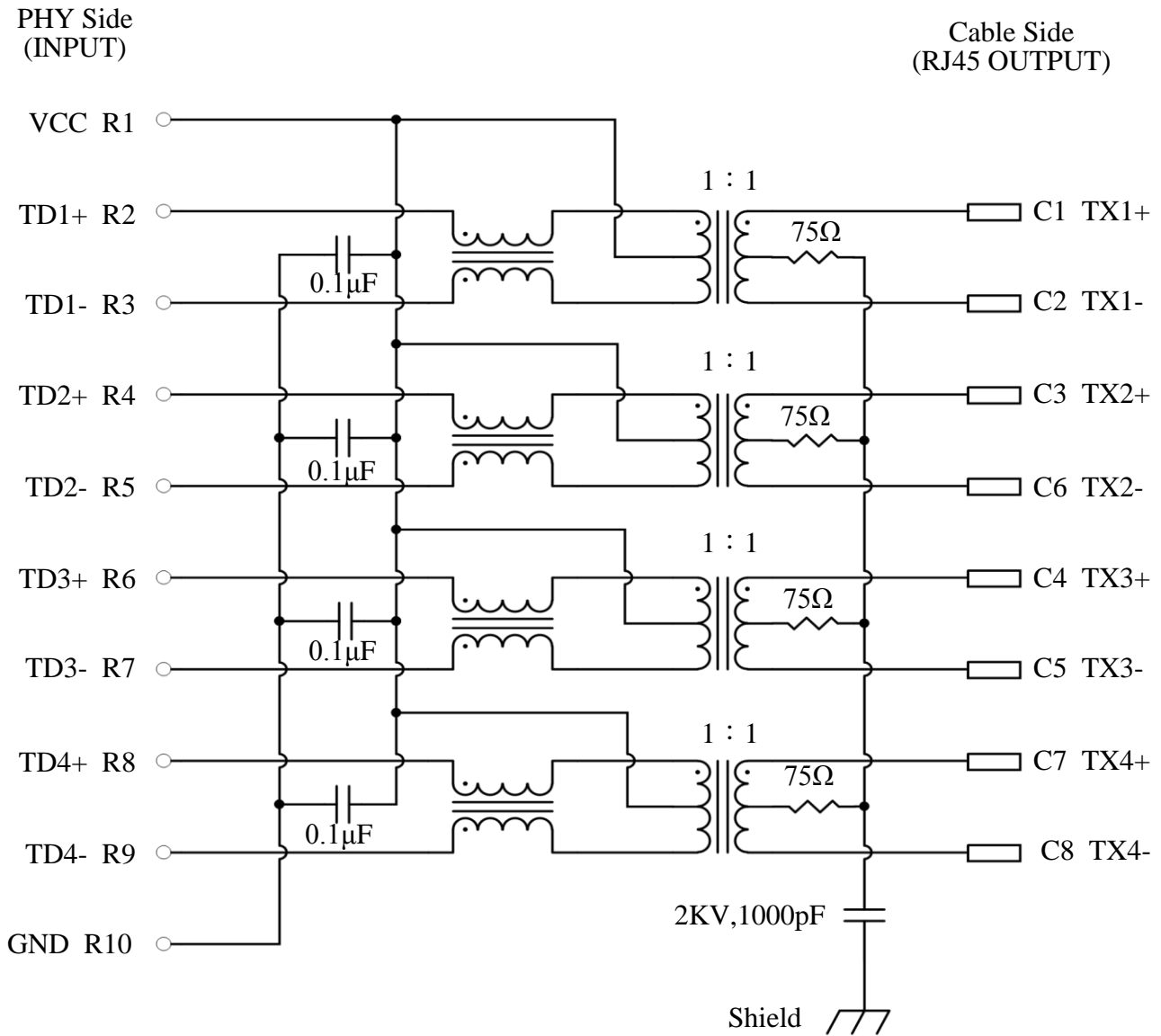

Emitting Color	λ_p (nm)	V_f @ $I_f=20mA$	I_r @ $V_r=5V$
Green	570	1.7 ~2.6 V	10 μ A max.
Orange	605	1.7 ~2.6 V	10 μ A max.

Transmitter filter & Receiver filter

Type : Balance low pass 100Ω impedance

Insertion loss : 1~100MHz -1.0dB max.

Return loss : 1~30MHz -18dB min. load 100Ω

30~60MHz -16dB min. load 100Ω

60~80MHz -12dB min. load 100Ω

80~100MHz -10dB min. load 100Ω

Common Mode Rejection

@1~100 MHz -30dB min.

Cross Talk

@ 1~100MHz -30dB min.

Inductance (OCL) @ 100KHz, 0.1V, 8mA DC BIAS

Input(TD1+,TD1-); (TD2+,TD2-); (TD3+,TD3-); (TD4+,TD4-) : 350 μH min.

HiPot Test

PHY Side(input) To Cable Side(output) : 1500Vac 60s or 2250Vdc 60s

10. WAVE SOLDERING TEMPERATURE PROFILE

Note :

The measuring point for the specified temperature shall be on the soldered part of the lead.

