

# APPROVAL SHEET

To :

Customer P/N :

UDE P/N : GSB-ZZ-0010

Description : RJ45 1X1 Tab Up

T/H, Slim, Sink

5G Base-T

Contact Area : 30 $\mu$ " Min. Gold

LED : L-Green; R-Yellow



Spec No.  
GSB19012-00

Update Date  
2019/6/19

Revision  
A

Approved	Checked	Prepared



湧德電子 股份有限公司  
UDE Corp.

桃園市(33852) 蘆竹區內溪路 68 巷13號

No.13, Ln. 68, Neixi Rd., Luzhu Dist., Taoyuan City (33852), Taiwan

TEL: 886-3-3242000 FAX: 886-3-3246611

<http://www.ude-corp.com/>

# Revision History

Issue Date	Revision	Comments	Operator
2019/6/19	A	Initial Release .	Guiying

1. MECHANICAL DIMENSION

Product Dimension

Unit:mm	General Tolerance :	X.X : ± 0.38
		X.XX : ± 0.20

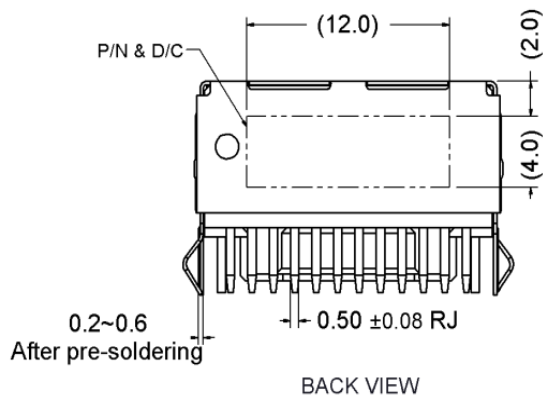
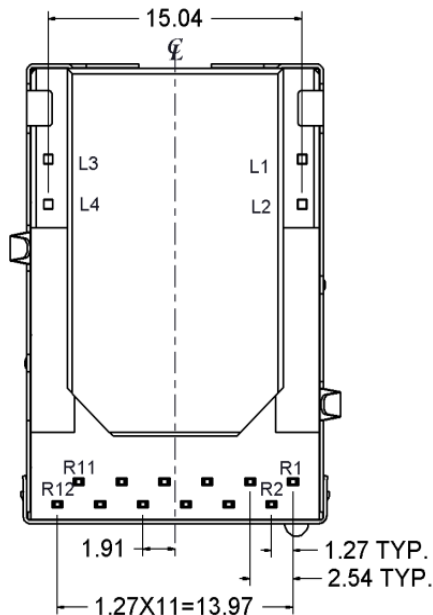
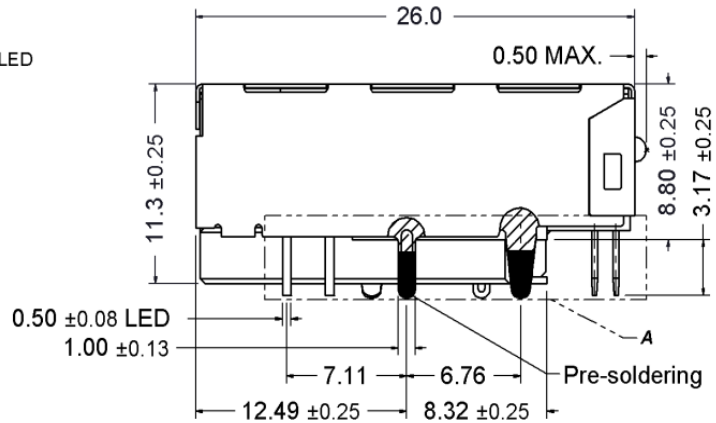
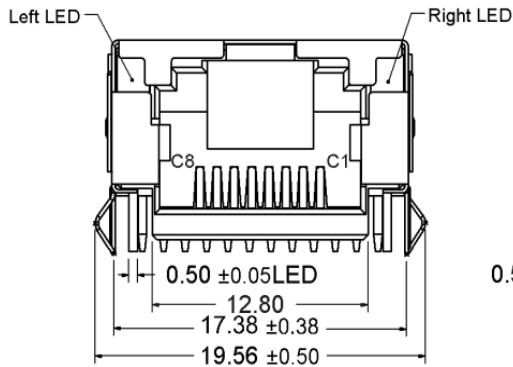
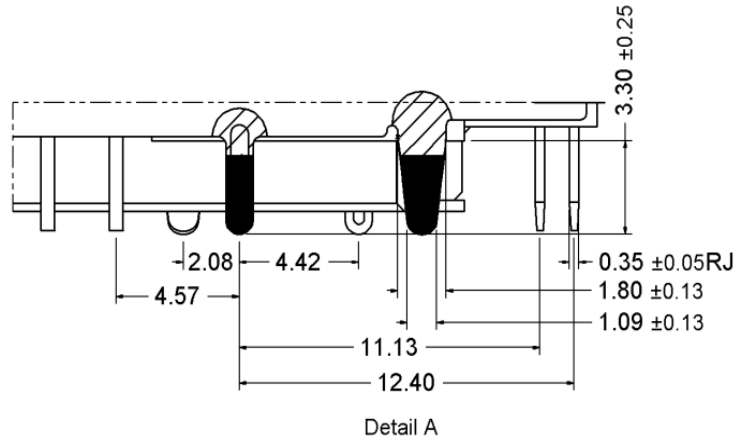
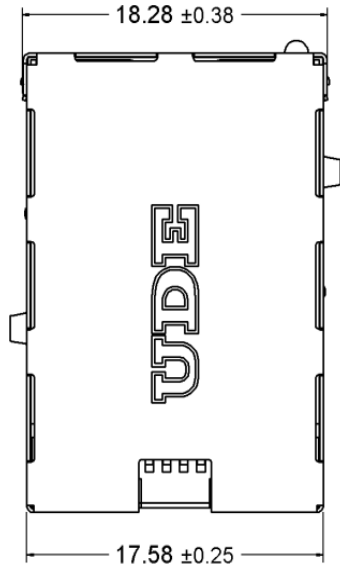

Recommended PCB Layout. Component side of board

All dimension units are "mm".

All dimension tolerances are  $\pm 0.05\text{mm}$  unless otherwise specified.

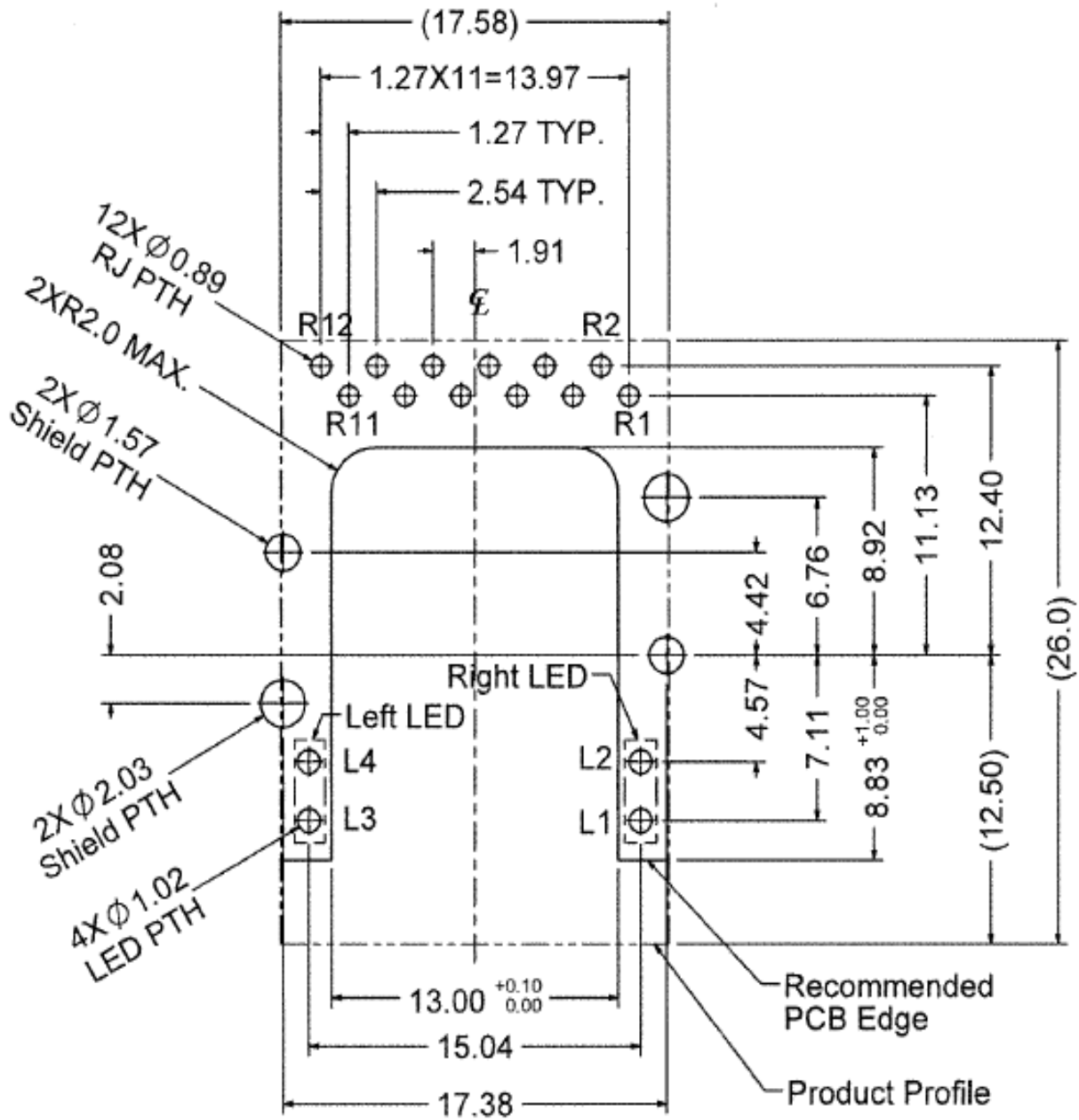

## Recommended Panel cutout

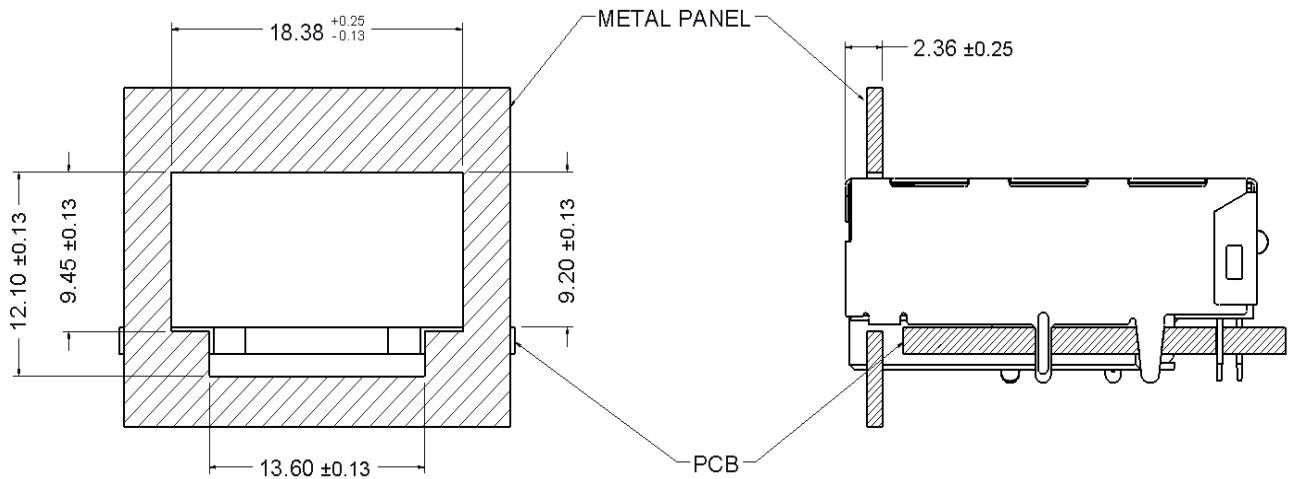

## 2. Packing Information

50 pcs finished goods per tray

7trays(350 pcs finished goods) per inner box

4 Inner boxes(1400 pcs finished goods) per master carton

### 3. Standard RJ45 Plug Specification

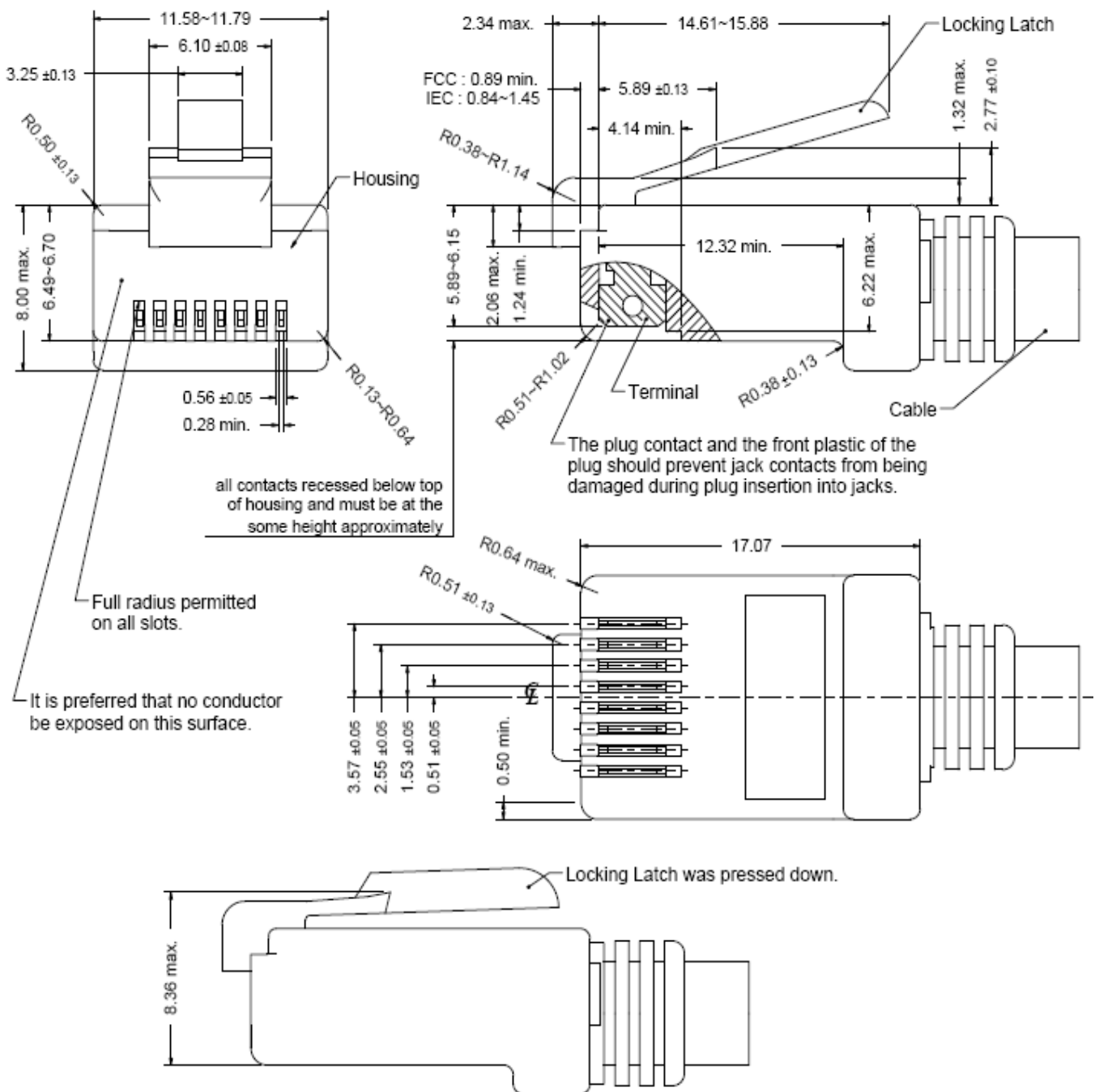

- All dimensions follow :  
FCC subpart F, 68,500, Figure (C)(2)(i) & (C)(2)(ii) & (C)(3)(i)  
IEC 60603-7
- All plugs must be meeting the requirements of plug Go & No-Go gauge.  
Gauge follow : FCC subpart F, 68,500, Figure (C)(4)(i) & (C)(5)(i)
- There must be no damage to Housing and Locking Latch.
- There must be no nicks and cuts in cable.
- Durability : 750 cycles generally

#### 4. REQUIREMENTS

##### Design and Construction

Product shall be of design, construction and physical dimensions specified on applicable.

##### Material

Terminal Parts (Underplating :50 $\mu$ " min. Nickel overall)

RJ Terminal : Phosphor Bronze, Thickness=0.30mm

Finish : Contact Area : 30 $\mu$ " min. Gold

Input Terminal : Brass, Thickness=0.35mm

Finish : 100 $\mu$ " min. Bright Tin

Case Terminal : Brass, Thickness=0.25mm

Finish : 100 $\mu$ " min. Bright Tin

Plastic Parts <UL94V-0>

Housing : PA6T, Black

Case : PA6T, Black

Shield Parts : Stainless steel, Thickness=0.20mm, Pre-soldering

## 5. Operating and Storage Temperature

Operating Temperature : 0°C to +70°C

Storage Temperature : -40°C to +85°C

## 6. RJ45 specifications

Insulation Resistance : 500MΩ min.

Insertion force with the latch depressed : 20N max.

Removal force with the latch depressed : 20N max.

Locking Force of Plug Latch : 50N min. @ 60+/-5 sec.

Durability : 2500 cycles

## 7. Performance and Test Description

Product is designed to meet electrical, mechanical and environmental performance requirements specified in below table.

All tests are performed at ambient environmental conditions per MIL-STD-1344A and EIA-364 unless otherwise specified.

## 8. Packaging and Packing

All parts shall be packaged and packed to protect against physical damage, corrosion and deterioration during shipment and storage.



9. ELECTRICAL CHARACTERISTICS @25°C

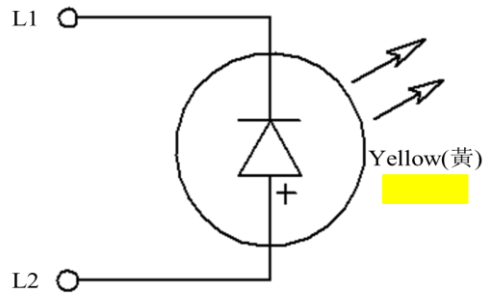
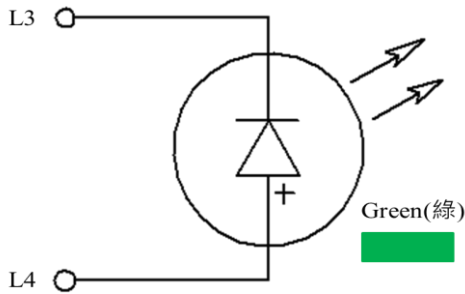
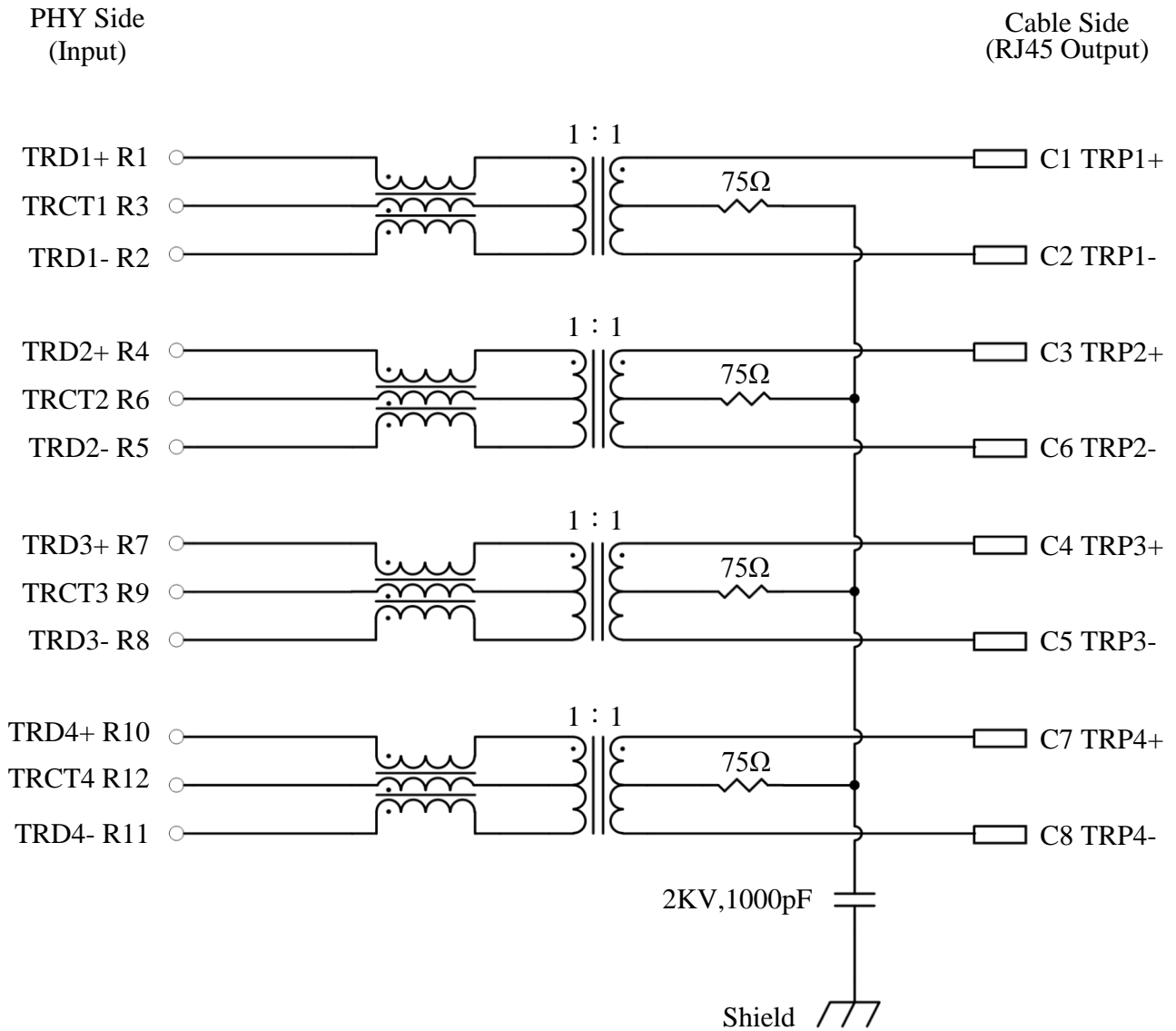

Emitting Color	$\lambda_p$ (nm)	$V_f$ @ $I_f=20mA$	$I_r$ @ $V_r=5V$
Green	570	1.7 ~2.6 V	10 $\mu$ A max.
Yellow	588	1.7 ~2.6 V	10 $\mu$ A max.

## Transmitter filter &amp; Receiver filter

Type : Balance low pass 100Ω impedance

Insertion loss :	1~50MHz	-0.5dB Max.
	50~125MHz	-1.0dB Max.
	125~200MHz	-2.0dB Max.
	200~250MHz	-2.5dB Max.

Return loss :	1~50MHz	-20dB Min.	load 100Ω
	50~250MHz	-20+15*log(Freq MHz/40MHz) dB Min load 100Ω	

## Reflected CM to Diff Conversion(REF)

1MHz	-30dB Min.
50MHz	-30dB Min.
100MHz	-27dB Min.
200MHz	-24dB Min.
250MHz	-23dB Min.

## CM to DM Conversion(REF)

1~50MHz	-35dB Min.
125MHz	-30dB Min.
200MHz	-27dB Min.
250MHz	-23dB Min.

## Reflected Diff to CM Conversion (REF)

1~10MHz	-48dB Min.
10~250MHz	-48+19*log(Freq MHz/10MHz) dB Min

## CM to CM Attenuation (REF)

1~200MHz	-25dB Min.
200~250MHz	-20dB Min.

## Cross Talk (REF)

1~125MHz	-30dB Min.
125~250MHz	-25dB Min.

Inductance @ 25°C, 100KHz, 100mV, 8mA DC BIAS

Input(TRD1+,TRD1-); (TRD2+,TRD2-); (TRD3+,TRD3-); (TRD4+,TRD4-):160uH Min.

HiPot Test

PHY Side(input) To Cable Side(output) : 1500Vac 60s or 2250Vdc 60s

### 10. WAVE SOLDERING TEMPERATURE PROFILE

Note :

The measuring point for the specified temperature shall be on the soldered part of the lead.

